

# Operating and installation instructions

## Steam combination oven

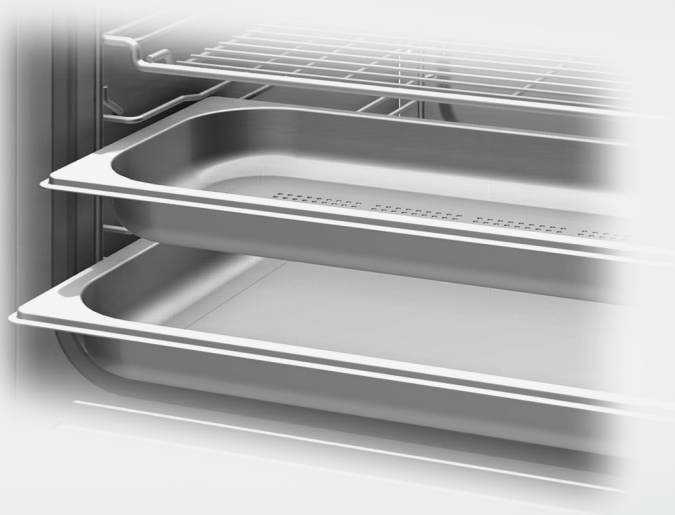

To avoid the risk of accidents or damage to the appliance it is **essential** to read these instructions before it is installed and used for the first time.

# Contents

---

<b>Warning and Safety instructions</b> .....	7
<b>Caring for the environment</b> .....	16
<b>Guide to the appliance</b> .....	17
Steam oven front view.....	17
Accessories supplied .....	19
<b>Controls</b> .....	21
Sensor controls .....	22
Display.....	23
Symbols.....	24
<b>Description of functions</b> .....	25
Control panel.....	25
Water container .....	25
Condensate container .....	25
Grease filter .....	25
Food probe.....	25
Temperature / Core temperature .....	25
Moisture .....	26
Duration.....	26
Noises.....	26
Heating-up phase.....	27
Cooking phase .....	27
Steam reduction .....	27
Oven interior lighting .....	27
<b>Using for the first time</b> .....	28
General settings .....	28
Cleaning for the first time .....	29
Set the water hardness level .....	30
Set the correct boiling point for water.....	31
Heating up the appliance .....	31
<b>Main and sub-menus</b> .....	32
<b>Operation: Steam cooking</b> .....	35
Simple operation .....	35
Interrupting operation.....	37
Advanced operation .....	38
Switching on and off automatically .....	39
Sequence of an automatic programme.....	39
Changing settings during a programme.....	40
Cancelling cooking.....	40



<b>Operation: Combination cooking mode</b> .....	41
Simple operation .....	42
Interrupting operation .....	44
Advanced operation .....	45
Switching on and off automatically .....	45
Sequence of an automatic programme .....	46
Changing settings during a programme .....	46
Cancelling cooking .....	46
<b>Operation: Functions without steam</b> .....	47
Simple operation .....	48
Interrupting operation .....	49
Advanced operation .....	50
Switching off automatically .....	51
Switching on and off automatically .....	51
Sequence of an automatic programme .....	52
Rapid heat-up .....	52
Changing the function .....	53
Changing settings during a programme .....	53
Cancelling cooking .....	54
<b>Automatic programmes</b> .....	55
List of food types .....	55
To use an Automatic programme .....	56
<b>User programmes</b> .....	57
To create a User programme .....	57
To start a User programme .....	59
To change a User programme .....	59
Changing cooking stages .....	59
Changing the name .....	60
To delete a User programme .....	60
<b>Minute minder</b>  .....	61
To set the minute minder .....	61
To change the duration set for the minute minder .....	61
To cancel the duration set for the minute minder .....	61
<b>General notes</b> .....	62
The advantages of cooking with steam .....	62
Suitable containers .....	62
Cooking containers .....	62
Your own containers .....	62
Shelf level .....	63

# Contents

---

Frozen food.....	63
Temperature .....	63
Duration .....	63
Cooking with liquid.....	63
Your own recipes - steam cooking.....	63
Combi rack / Universal tray.....	64
<b>Steam cooking.....</b>	<b>65</b>
Vegetables.....	65
Meat .....	68
Sausages.....	70
Fish.....	70
Shellfish .....	73
Mussels .....	74
Rice .....	75
Pasta .....	76
Dumplings .....	77
Grain .....	78
Dried pulses .....	79
Hen's eggs .....	81
Fruit .....	82
Menu cooking (cooking whole meals) - manually .....	83
<b>Sous-vide (vacuum) cooking.....</b>	<b>85</b>
Reheating .....	91
<b>Special applications.....</b>	<b>93</b>
Reheat .....	93
Defrost.....	95
Bottling .....	98
Bottling cakes.....	101
Extracting juice with steam .....	102
Menu cooking (cooking whole meals).....	103
Drying food.....	104
Make yoghurt .....	105
Prove dough .....	106
Dissolve gelatine .....	107
Melt chocolate.....	107
Skinning vegetables and fruit.....	108
Apple storage .....	109
Blanching.....	109
Sweat onions.....	110
Cook bacon.....	110
Disinfect items .....	111

---

Heat damp flannels .....	111
Decrystallise honey .....	112
Pizza .....	112
Making eierstich .....	112
Making preserves .....	113
Sabbath programme .....	114
<b>Food probe</b> .....	<b>115</b>
<b>Roasting</b> .....	<b>118</b>
<b>Baking</b> .....	<b>126</b>
<b>Grilling</b> .....	<b>133</b>
<b>Settings</b> .....	<b>136</b>
Opening the Settings menu.....	136
Changing and saving settings .....	136
Settings overview .....	137
Language  .....	138
Time of day.....	138
Display.....	138
Clock format.....	138
Setting the time .....	138
Date .....	138
Lighting.....	139
Display brightness.....	139
Acoustic information .....	139
Melody.....	139
Solo tone .....	139
Keypad tone .....	140
Units .....	140
Weight .....	140
Temperature .....	140
Keeping warm .....	141
Recommended temperatures.....	142
Safety .....	142
System lock  .....	142
Sensor lock .....	143
Water hardness .....	143
Showroom programme.....	144
Demo mode.....	144
Factory default.....	144

# Contents

---

<b>Note for test institutes</b> .....	145
<b>Cleaning and care</b> .....	147
Important information on cleaning and care .....	147
Appliance front .....	148
PerfectClean .....	149
Oven interior .....	150
Water container and condensate container .....	152
Accessories .....	152
Side runners .....	153
Maintenance.....	154
Soak .....	154
Drying .....	154
Rinsing.....	154
Descaling.....	154
Door.....	156
<b>Problem solving guide</b> .....	158
<b>Optional accessories</b> .....	163
Cooking containers .....	163
Cleaning and care products .....	165
Miscellaneous.....	166
<b>Miele@home</b> .....	168
<b>Safety instructions for installation</b> .....	170
<b>Detailed dimensions of oven front</b> .....	171
<b>Building-in dimensions</b> .....	173
Installation in a tall unit.....	173
Installation in a base unit.....	175
<b>Installation</b> .....	177
<b>Electrical connection</b> .....	178
<b>After sales service, data plate, guarantee</b> .....	180

## Warning and Safety instructions

The steam combination oven is referred to in the following instructions as a steam oven.

This appliance complies with statutory safety requirements. Inappropriate use can, however, lead to personal injury and damage to property.

To avoid the risk of accidents and damage to the appliance, please read these instructions carefully before using it for the first time. They contain important notes on installation, safety, use and maintenance.

Miele cannot be held liable for damage caused by non-compliance with these instructions.

Keep these instructions in a safe place and ensure that new users are familiar with the contents. Pass them on to any future owner.

## Warning and Safety instructions

---

### Correct application

- ▶ This steam oven is intended for use in domestic households and similar working and residential environments.
- ▶ This steam oven is not intended for outdoor use.
- ▶ This steam oven is intended for domestic use only as described in these operating instructions.  
Any other usage is not supported by the manufacturer and could be dangerous.
- ▶ The steam oven can only be used by people with reduced physical, sensory or mental capabilities, or lack of experience and knowledge, if they are supervised whilst using it, or have been shown how to use it in a safe way and recognise and understand the consequences of incorrect operation.
- ▶ This steam oven is supplied with a special lamp to cope with particular conditions (e.g. temperature, moisture, chemical resistance, abrasion resistance and vibration). This special lamp must only be used for the purpose it is intended for. It is not suitable for room lighting. Replacement lamps may only be fitted by a Miele authorised person or by Miele Service.

## Safety with children

- ▶ Activate the system lock to ensure that children cannot switch on the steam oven inadvertently.
- ▶ Children under 8 years of age must be kept away from the appliance unless they are constantly supervised.
- ▶ Children 8 years and older may only use the steam oven unsupervised if they have been shown how to use it safely and recognise and understand the consequences of incorrect operation.
- ▶ Children must not be allowed to clean the steam oven unsupervised.
- ▶ Please supervise children in the vicinity of the steam oven and do not let them play with it.
- ▶ Danger of suffocation. Packaging, e.g. plastic wrappings, must be kept out of the reach of babies and children. Whilst playing, children could become entangled in packaging or pull it over their head and suffocate.
- ▶ Danger of burning. Children's skin is far more sensitive to high temperatures than that of adults. The door glass, the control panel and the ventilation outlet above the oven door all get hot. Make sure that children do not touch the steam oven or attempt to open the door when it is in operation. Keep children well away from the appliance until it has cooled down and there is no danger of burning.
- ▶ Danger of injury. The door can support a maximum weight of 10 kg.  
Do not let children sit on the door, lean against it or swing on it. They could injure themselves.

# Warning and Safety instructions

---

## Technical safety

- ▶ Unauthorised installation, maintenance and repairs can cause considerable danger for the user. Installation, maintenance and repairs must only be carried out by a Miele authorised technician.
- ▶ Never use a damaged steam oven. It could be dangerous. Check it for visible signs of damage before using it.
- ▶ Reliable and safe operation of this steam oven can only be assured if it has been connected to the mains electricity supply.
- ▶ The electrical safety of this appliance can only be guaranteed when correctly earthed. It is essential that this standard safety requirement is met. If in any doubt please have the electrical installation tested by a qualified electrician.
- ▶ Before connecting the appliance to the mains supply, ensure that the connection data on the data plate (voltage and frequency) match the mains electricity supply.  
This data must correspond in order to avoid the risk of damage to the appliance. Consult a qualified electrician if in any doubt.
- ▶ Do not connect the steam oven to the mains electricity supply by a multi-socket adapter or an extension lead. These do not guarantee the required safety of the appliance (fire hazard).
- ▶ For safety reasons, this steam oven may only be used when it has been built in. This is necessary to ensure that all electrical components are shielded.
- ▶ This steam oven must not be used in a non-stationary location (e.g. on a ship).
- ▶ Never open the casing of the appliance. Tampering with electrical connections or components and mechanical parts is highly dangerous to the user and can cause operational faults.

## Warning and Safety instructions

---

- ▶ While the appliance is under guarantee, repairs should only be undertaken by a Miele authorised service technician. Otherwise the guarantee is invalidated.
- ▶ Miele can only guarantee the safety of the appliance when genuine original Miele replacement parts are used. Faulty components must only be replaced by Miele spare parts.
- ▶ If the plug is removed from the connection cable or if the cable is supplied without a plug, the appliance must be connected to the electrical supply by a suitably qualified electrician.
- ▶ If the connection cable is damaged, it must be replaced by a suitably qualified electrician with a special connection cable of type H 05 VV-F (pvc insulated). See "Electrical connection".
- ▶ During installation, maintenance and repair work, the appliance must be disconnected from the mains electricity supply.
- ▶ If the steam oven is installed behind a furniture panel (e.g. a door), ensure that the door is never closed whilst the steam oven is in use. Heat and moisture can build up behind a closed furniture panel and cause subsequent damage to the steam oven, the housing unit and the floor. Do not close the door until the steam oven has cooled down completely.
- ▶ In areas which may be subject to infestation by cockroaches or other vermin, pay particular attention to keeping the appliance and its surroundings in a clean condition at all times. Any damage which may be caused by cockroaches or other vermin will not be covered by the guarantee.

# Warning and Safety instructions



---

## Correct use

- ▶ Danger of burning. The steam oven becomes hot when in use. You could burn yourself on the heating elements, oven interior, cooked food, oven accessories or hot steam. Wear oven gloves when placing food in the oven or removing it and when adjusting oven shelves etc. in a hot oven. Take care when putting cooking containers into the oven or removing them not to spill the contents.
- ▶ Do not use the steam oven to heat up or bottle food in sealed jars and tins. Pressure will build up inside them and they can explode causing damage to the appliance, as well as the risk of injury and scalding.
- ▶ Plastic containers which are not suitable for use in an oven melt at high temperatures and can damage the steam oven or catch fire. Only use plastic containers which are declared by the manufacturer as being suitable for use in an oven. Follow the manufacturer's instructions on use. If you want to use plastic containers for steaming food make sure that they are temperature resistant to 100 °C and steam resistant. Any other plastic containers could melt, become brittle or break when subjected to heat.
- ▶ Food which is left in the oven to be kept hot can dry out and the moisture released can lead to corrosion damage in the appliance. Do not use the steam oven for keeping food warm and do not use utensils in the appliance which could corrode.
- ▶ You could injure yourself on the open steam oven door or trip over it. Avoid leaving the door open unnecessarily.
- ▶ The door can support a maximum weight of 10 kg. Do not sit on or lean against an open door, and do not place heavy objects on it. Also make sure that nothing can get trapped between the door and the oven cavity. The steam oven could get damaged.

## Warning and Safety instructions

---

- ▶ Oil and fat can ignite if overheated. Never leave the steam oven unattended when cooking with oil and fat.  
If it does ignite do not put the flames out with water. Switch the steam oven off immediately and then suffocate the flames by keeping the oven door closed.
- ▶ Due to the high temperatures radiated, objects left near the steam oven when it is in use could catch fire.  
Do not use the steam oven to heat up the room.
- ▶ Grilling food for an excessively long time can cause it to dry out with the risk of catching fire.  
Do not exceed recommended grilling times.
- ▶ Some types of food dry out quickly and can self-ignite if high grill temperatures are used.  
Never use the grill to finish baking part-cooked rolls or bread or to dry flowers or herbs. Use Fan plus  or Conventional heat  for this type of procedure.
- ▶ To avoid fuelling any flames, do not open the oven door if smoke occurs inside the appliance. Interrupt the process by switching the appliance off and disconnect it from the mains electricity supply. Do not open the door until the smoke has dispersed.
- ▶ If using alcohol in your recipes, please be aware that high temperatures can cause the alcohol to vaporise. The vapour can catch fire on hot heating elements.
- ▶ Never cover the floor of the oven with aluminium foil, or place oven dishes, pans, saucepans or trays directly onto the floor of the oven.
- ▶ Never use the oven without the filter in the bottom of the oven in place. It will prevent coarse food residues from blocking the drainage system and the pump.
- ▶ To prevent the risk of damage do not leave the food probe in the oven when it is not being used.

## Warning and Safety instructions

---

▶ When using a small electrical appliance, e.g. a hand-held blender, near the steam oven, care should be taken that the cable of the appliance cannot get trapped by the steam oven door. The insulation on the cable could become damaged, giving rise to an electric shock hazard.

▶ Do not operate the steam oven without the lamp cover. Steam could reach electrical components and cause a short circuit. Steam could also damage the electrical components.

### Cleaning and care

- ▶ Do not use a steam cleaning appliance to clean this appliance. The steam could reach electrical components and cause a short circuit.
- ▶ Scratches on the door glass can result in the glass breaking. Do not use abrasive cleaners, hard sponges, brushes or sharp metal tools to clean the door glass.
- ▶ The side runners can be removed for cleaning purposes (see "Cleaning and care"). Ensure that they are replaced correctly and do not use the oven without them fitted.
- ▶ Try to avoid the interior walls being splashed with food or liquids containing salt. If it does happen, wipe these away thoroughly to avoid corrosion to stainless steel surfaces inside the cabinet.

### Accessories

- ▶ Only use genuine original Miele accessories and spare parts with this appliance. Using accessories or spare parts from other manufacturers will invalidate the guarantee, and Miele cannot accept liability.
- ▶ Only use the Miele food probe supplied with this oven. If it is faulty, it must only be replaced with a suitable original Miele food probe.
- ▶ The plastic on the food probe can melt at very high temperatures. Do not use the food probe when using the grill functions (exception: Fan Grill ). Do not store the food probe in the oven if it is not in use.

# Caring for the environment

---

## Disposal of the packing material

The packaging is designed to protect the appliance from damage during transportation. The packaging materials used are selected from materials which are environmentally friendly for disposal and should be recycled.

Recycling the packaging reduces the use of raw materials in the manufacturing process and also reduces the amount of waste in landfill sites.

## Disposing of your old appliance

Electrical and electronic appliances often contain valuable materials. They also contain specific materials, compounds and components, which were essential for their correct function and safety. These could be hazardous to human health and to the environment if disposed of with your domestic waste or if handled incorrectly. Please do not, therefore, dispose of your old appliance with your household waste.



Please dispose of it at your local community waste collection / recycling centre for electrical and electronic appliances, or contact your dealer or Miele for advice. You are also responsible by law for deleting any personal data that may be stored on the appliance being disposed of. Please ensure that your old appliance poses no risk to children while being stored prior to disposal.

## Steam oven front view

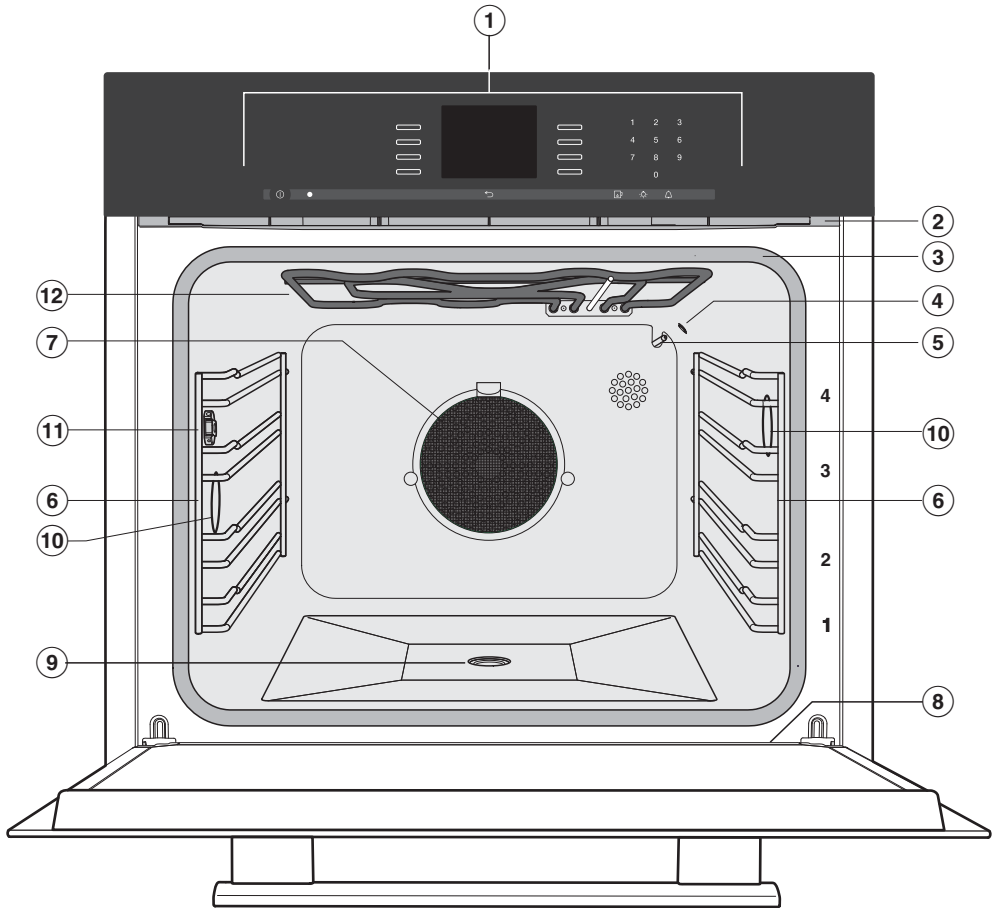

- |                                    |                                        |
|------------------------------------|----------------------------------------|
| ① Controls                         | ⑦ Grease filter                        |
| ② Ventilation outlet               | ⑧ Drip channel                         |
| ③ Door seal                        | ⑨ Drain                                |
| ④ Moisture sensor                  | ⑩ Oven interior lighting               |
| ⑤ Temperature sensor               | ⑪ Connection socket for the food probe |
| ⑥ Side runners with 4 shelf levels | ⑫ Top heat/grill element               |

## Guide to the appliance

---

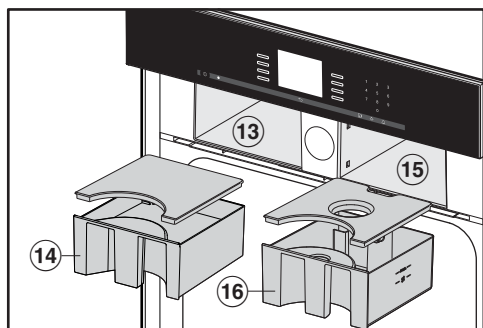

- ⑬ Condensate container compartment
- ⑭ Condensate container
- ⑮ Compartment for water container
- ⑯ Water container

## Accessories supplied

The accessories supplied with your appliance as well as a range of optional ones are available to order from Miele (see "Optional accessories").

### DGG 20

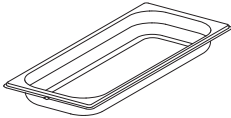

1 solid cooking container  
Gross capacity 2.4 l / Usable capacity 1.8 l  
450 x 190 x 40 mm (W x D x H)

### DGGL 20

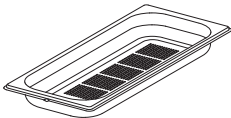

1 perforated cooking container  
Gross capacity 2.4 litres / Usable capacity 1.8 litres  
450 x 190 x 40 mm (W x D x H)

### DGGL 12



1 perforated cooking container  
Gross capacity 5.4 litres / Usable capacity 3.3 litres  
450 x 390 x 40 mm (W x D x H)

## Universal tray

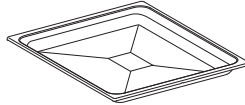

1 universal tray for baking, roasting and grilling

## Combi rack



1 combi rack for baking, roasting and grilling

## Food probe

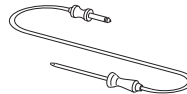

Food probe for precise temperature controlled cooking. The food probe monitors the inner temperature of the meat (core temperature).

## DGCLean



Special cleaning agent for removing stubborn soiling from the oven interior, particularly after roasting.

## Descaling tablets

For descaling the appliance





# Guide to the appliance

---

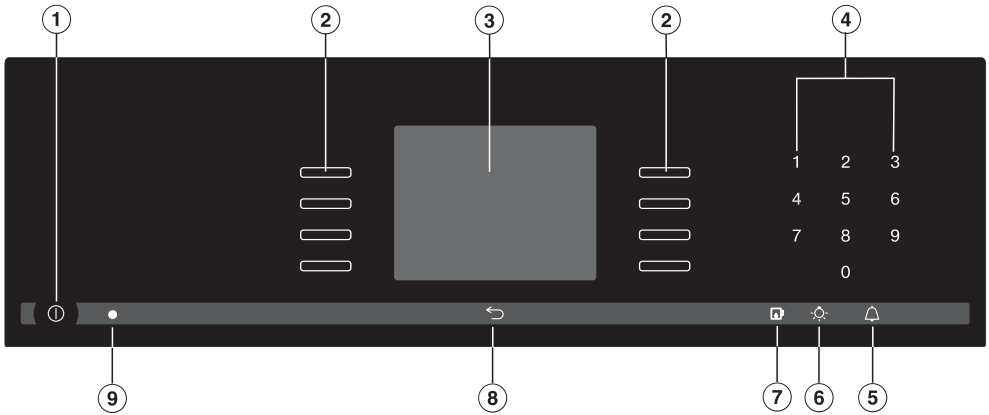
## **Miele steam combination oven cookbook**

A selection of the best recipes from the Miele test kitchen.











- ① Recessed On/Off button ①  
For switching on and off
- ② Sensors   
For selecting functions, menu options and settings
- ③ Display  
Displays time of day and information for operation
- ④ Sensor controls 0–9  
Numerical keypad to enter values
- ⑤  sensor  
For setting the minute minder
- ⑥  sensor  
For switching the oven interior lighting on and off
- ⑦  sensor  
For opening/closing the control panel
- ⑧  sensor  
To go back one step at a time
- ⑨ Optical interface  
(for Miele service technician use only)

# Controls

## Sensor controls

The sensors react to touch. Each touch is confirmed with a keypad tone. This keypad tone can be switched off (see "Settings – Keypad tone").



Sensor	Function	Notes
	For selecting options and scrolling through the list of options.	Touch the illuminated  sensor beside the option to select it.
0–9	Numerical keypad for setting values	The numerical keypad is used to set values, e.g. temperatures and durations.
	For setting the minute minder	If a list of options is showing in the display or if a cooking programme is running, you can enter a minute minder duration (e.g. when boiling eggs) at any point (see "Minute minder  ").  If the display is dark, this sensor will not react until the steam oven is switched on.
	For switching the oven interior lighting on and off	If a list of options is showing in the display or if a cooking process is running, touching  will switch the oven interior lighting on or off.  If the display is dark, this sensor will not react until the steam oven is switched on.  The oven interior lighting switches off after 15 seconds during a cooking process or remains constantly switched on, depending on the setting selected.
	For opening and closing the control panel	
	To go back a step	

## Display

The display is used for showing the time of day or information about functions, temperatures, cooking durations, automatic programmes and settings. Information or a list of options is shown in the display depending on the function selected.

After switching the steam oven on with the On/Off sensor , the main menu will appear.

If a cooking process is running, selecting **Change** will call up a list of options which can be set or changed for the cooking process in progress.





- Touch the illuminated  sensor beside the option to select it.
- Then confirm the selection by touching the illuminated  sensor next to OK.

# Controls

---

## Symbols

The following symbols may appear in the display:

Symbol	Explanation
-	Allocates an illuminated  to an option and indicates that the option can be selected.
	If more than four options are available a bar will appear on the right-hand side of the display. Use the allocated sensors to scroll through the list.
.....	The end of a list is indicated by a dotted line. By scrolling down further, you reach the beginning of the list again.
+ / -	These only appear when input is possible or necessary (e.g. entering the date / setting the grill level).
✓	A tick shows that a setting is active. "-" will not appear in front of it and the sensor belonging to it will not be illuminated.
i	This symbol indicates that there is additional information and advice about using the oven. Select <i>OK</i> to access the information.
	Water level indicator
	Programme finished
	Minute minder
	Some settings, e.g. display brightness and buzzer volume are selected using a bar chart.

## Control panel

The water container and condensate container are located behind the control panel. The control panel is opened and closed using the  sensor. The panel is fitted with a device which will automatically stop it moving if it meets an obstruction whilst opening or closing. Do not touch the door handle whilst the panel is opening or closing!

## Water container

The maximum water level is 1.4 litres, the minimum 1.0 litre. These levels are indicated on the container. Do not exceed the maximum level.

The amount of water used will depend on the type of food and the duration of cooking. Water will sometimes need to be replenished during the cooking programme. Water consumption is increased if the door is opened during cooking.

Fill the water container to the maximum level before each use.

## Condensate container

Condensate that collects in the appliance from cooking is pumped into the condensate container. The container has a maximum capacity of 1.4 litres.

## Grease filter

Fit the grease filter in the back wall for all roasting programmes.

It should be removed when using steam programmes.

It must also be removed when baking, as otherwise results can be uneven.

(Exception: fit the grease filter in the back wall when baking open deep fresh fruit flans, e.g. plum or damson or pizza with lots of topping).

## Food probe

The food probe measures the core temperature in the food, enabling the temperature during the cooking process to be monitored simply and accurately.

## Temperature / Core temperature

Some functions have a default recommended temperature. This recommended temperature can be altered within the given range for the programme or programme stage in use, or for every time that programme is used (see "Settings - Recommended temperatures").

The core temperature can also be changed within a given range for an individual cooking process or cooking stage.

# Description of functions

---

## Moisture

The Combi mode and Reheat functions use a combination of oven heat and moisture. You can alter the moisture level within a given range for an individual cooking programme or a cooking stage.

Depending on the moisture setting for the programme, either moisture or fresh air is injected into the oven. If the moisture level is set to 0 %, the maximum amount of air will be injected and no moisture. If the moisture level is set to 100 %, air will not be injected into the oven and the maximum amount of moisture will be injected.

Some food gives off moisture during the cooking process. This moisture from the food also controls the amount of moisture needed. If the required amount of moisture is very low and the food already contains a lot of water the steam generator may not be activated at all.

## Duration

Depending on the function, you can set a cooking duration of between 1 minute and 6, 10 or 12 hours.

The duration of the Automatic, Maintenance and Menu cooking programmes is set at the factory and cannot be altered.

With the Steam cooking function and programmes that use steam alone, the cooking duration does not start to count down until the set temperature has been reached. It begins immediately with all other functions and programmes.

## Noises

You will hear a pumping sound when the appliance is switched on, during use and after switching it off. This is the sound of water being pumped through the system and is quite normal.

When the steam oven is in use, you will hear a fan noise.

## Heating-up phase

During the heating-up phase the display will show the temperature in the cooking compartment as it rises and Heating-up phase in all programmes except for Automatic progs., Menu cooking and Maintenance.

When cooking with steam, the duration of the heating-up phase will depend on the quantity and the temperature of the food. In general the heating-up phase will last for approx. 7 minutes. The duration will be longer if you are cooking refrigerated or frozen food.

## Cooking phase

The cooking phase begins when the set temperature is reached. During the cooking phase, the duration remaining will be shown in the display.

## Steam reduction

With steam cooking and combi cooking, the steam reduction function will switch on automatically at the end of a cooking programme which uses a temperature within a certain temperature range. This reduces the amount of steam which escapes when the door is opened. Steam reduction will appear in the display in addition to Process finished.

This function can be switched off if you wish (see "Settings - Steam reduction").

## Oven interior lighting

For energy saving reasons, the oven compartment lighting has been set at the factory to go out after the programme has begun.

If you want it to stay on all the time the oven is on you will need to alter the default setting (see "Settings - Lighting").

If the door is left open at the end of a cooking programme the oven lighting will switch off automatically after 5 minutes.

The lighting radiates heat. It will switch itself off automatically when you are cooking with a temperature below 50 °C.

If the  sensor on the control panel is touched, the oven compartment lighting will come on for 15 seconds.

# Using for the first time

---

## General settings

 The steam oven must not be operated until it has been correctly installed in its housing unit.

The steam oven will switch on automatically when it is connected to the electricity supply.

## Welcome screen

A welcome greeting is displayed. You will then be asked to select some basic settings which are needed before the appliance can be used.

- Follow the instructions in the display.

## Set the language

- Scroll through the list until the language you want appears.
- Touch the illuminated  sensor next to the language you want to select.
- Confirm with OK.

## Select the country

- Scroll through the list until the country you want appears.
- Touch the illuminated  sensor next to the country you want to select.
- Confirm with OK.

## Set the date

- Use + or – to set the year, month and day.
- Confirm each with OK.

## Set the time of day

- Use the numerical keypad to set the time of day in hours and minutes (e.g. 1-2-1-5 for 12:15).
- Confirm with OK.

The time of day can be displayed in 12 hour format (see "Settings - Time of day - Clock format").

## Time of day display

You will then be asked how you want the time of day to show in the display when the steam oven is switched off (see "Settings - Time of day - Display"):

– On

The time always shows in the display.

– Off

The display appears dark to save energy. Some functions are limited.

– Night dimming

The time only shows in the display between 5:00 and 23:00. It switches off at night to save energy.

■ Select the option you want.

■ Confirm with OK.

Some information about energy consumption will appear in the display.

■ Confirm with OK.

Set up successfully completed will appear.

■ Confirm with OK.

The steam oven is ready for use.

If you have selected the wrong language by mistake proceed as described in "Settings - Language ".

- Please stick the extra data plate for the appliance supplied with this documentation in the space provided in the "After sales service, data plate, guarantee" section of this booklet.
- Remove any protective wrapping and stickers.

The appliance has undergone a function test in the factory. Residual water from this testing may have trickled back into the cabinet during transportation.

## Cleaning for the first time

### Water container and condensate container

 Danger

Do not touch the door handle when opening the control panel. You could trap your fingers.

- Touch  to open the control panel.
- Remove the water container and condensate container. Push upwards slightly as you take them out of the appliance.
- Rinse the water container / condensate container by hand or in the dishwasher.

# Using for the first time

---

## Accessories / Oven interior

- Take all accessories out of the oven.
- Wash the stainless steel cooking containers in a mild solution of washing-up liquid and hot water or in the dishwasher.

Risk of damage to the surfaces of the universal tray and the combi rack.

The universal tray and combi rack are treated with PerfectClean and must **only** be cleaned by hand. See "Cleaning and care - PerfectClean" for more information.

- Clean the universal tray and the combi rack with a clean sponge and a solution of hot water and washing-up liquid.

The interior of the steam oven has been treated at the factory with a conditioning agent.

- To remove this, clean the oven interior with a mild solution of washing-up liquid and hot water.

## Set the water hardness level

The steam oven is set ex-works for Hard water. It must be adjusted to local water hardness to ensure trouble-free operation and to ensure that descaling is carried out at the correct interval. The harder the water, the more often it will need to be descaled.

- Check the hardness of your local water supply and adjust the water hardness as necessary (see "Settings - Water hardness").

## Set the correct boiling point for water

Before cooking food for the first time, you must set the boiling point for water, as this varies depending on the altitude the appliance is located at. This procedure also flushes out the waterways.

This procedure **must** be carried out to ensure efficient functioning of your appliance.

**Only use cold mains tap water** (less than 20 °C). Never use distilled or mineral water or other liquids.

- Remove the water container (on the right) and fill it up to the maximum marker.
- Push the water container into the appliance until it connects.
- You should then run the *Steam cooking* programme at 100 °C for 15 minutes. Proceed as described in "Operation: Steam cooking".

## Set the correct boiling point for water following a house move

If you move house, the appliance will need to be re-set for the new altitude if this differs from the old one by 300 m or more. To do this, descale the appliance (see "Cleaning and care / Maintenance / Descaling").

## Heating up the appliance

- To remove the grease from the ring heating element, heat the appliance up with nothing in it at 200 °C using the *Fan plus* function for 30 minutes. Proceed as described in "Operation: Functions without steam".

There will be a slight smell the first time the heating element is heated up. The smell and any vapours will dissipate after a short time, and do not indicate a faulty connection or appliance.

It is important to ensure that the kitchen is well ventilated during this operation.

## Main and sub-menus

	Recommended temperature/ Setting	Temperature range
Oven functions		
Fan plus For baking on several levels	160 °C	30–225 °C
Conventional heat For baking traditional recipes, e.g. rich fruit cake and soufflés	180 °C	30–225 °C
Combi mode For baking, roasting and grilling		
Fan plus	170 °C	30–225 °C
Conventional heat	180 °C	30–225 °C
Full grill	Level 3	Level 1-3
Steam cooking Suitable for all types of food, bottling, extracting juice with steam and special applications	100 °C	40–100 °C
Sous-vide For cooking food in a vacuum sealing bag	65 °C	45–90 °C
Intensive bake For cooking dishes which require a moist topping and a crisp base	180 °C	50–225 °C
Bottom heat Use this setting towards the end of baking, to brown the base of a cake, quiche or pizza.	190 °C	100–225 °C
Top heat Use this setting towards the end of baking to brown the top of bakes, gratins etc.	190 °C	100–225 °C

## Main and sub-menus

	Recommended temperature/ Setting	Temperature range
Oven functions		
Full grill For grilling thin cuts in large quantities and for browning large baked dishes	Level 3	Level 1-3
Economy grill For grilling thin cuts in small quantities and for browning small baked dishes	Level 3	Level 1-3
Fan grill For grilling thicker items, e.g. rolled meat, poultry pieces.	200 °C	50–225 °C
Cake plus For creamed mixtures, choux pastry (e.g. eclairs) and frozen pretzels.	160 °C	30–225 °C
Gentle bake For cooking sweet and succulent bakes and gratins	160 °C	30–225 °C
Automatic programmes		
This option will bring up a list of all Automatic programmes available on this oven		
Special applications		
Menu cooking For cooking different types of food at the same time	–	–
Pizza	180 °C	180–225 °C
Defrost For gentle defrosting of frozen food	60 °C	50–60 °C
Reheat For gentle reheating of cooked food	130 °C	120–140 °C

## Main and sub-menus

	Recommended temperature/ Setting	Temperature range
Special applications		
Blanching	–	–
Bottling	90 °C	80–100 °C
Disinfect items	–	–
Drying	60 °C	60–70 °C
Prove dough	–	–
Sabbath programme	180 °C	30–225 °C
User programmes		
You can save your own cooking programmes with this option		
Settings 		
For changing default settings		
Maintenance		
Descal	–	–
Soak	–	–
Drying	–	–
Rinses	–	–

## Operation: Steam cooking

A malfunction can occur if the drain is blocked.

Before each cooking programme ensure that the filter in the bottom of the cooking compartment is correctly fitted. Otherwise coarse soiling could get into the drainage system and cause a blockage.

### Simple operation

- Switch the steam oven on using ①.

The main menu appears in the display.

**Only use cold mains tap water** (less than 20 °C). Never use distilled or mineral water or other liquids.

- Fill the water container and push it back in so that it connects.
- Place the food in the oven.
- Select Oven functions.
- Select Steam cooking.

Set the temperature appears in the display.

- Change the recommended temperature if necessary.
- Confirm with OK.

The recommended temperature will be automatically accepted within a few seconds.

If required, select ↶ to go back to the temperature selection option.

Set the duration appears in the display.

- Set the cooking duration. Any time between 1 minute and 10 hours can be set.
- Confirm with OK.

The cooking process begins. The steam generator, lighting and fan switch on.

- Set further settings as necessary (see "Advanced operation")

# Operation: Steam cooking

---

## At the end of the cooking duration

- Steam reduction (only with temperatures over approx. 80 °C) and Process finished will appear in the display,
- the fan remains switched on,
- a tone or melody will sound (see "Settings - Acoustic information")

You have the option of saving your settings as a User programme (see "User programmes") or increasing the cooking duration via Change. Touch ↵ to go to the main menu.



### Danger of burning.

You could burn yourself on the oven interior walls, spilled food and accessories.

Use oven gloves when removing hot food from the oven.

- Wait until Steam reduction goes out in the display before opening the door and removing the food.

## After use

- Remove and empty the water container and condensate container. Push upwards slightly as you take them out of the appliance.
- Switch the steam oven off using ①.

Following a cooking programme with steam Appliance rinsing will appear in the display after the steam oven has been switched off.

This process should be carried out every time to flush any remaining food deposits out of the system.

- Follow the instructions in the display.
- After each use, clean and dry the whole appliance as described in "Cleaning and care".
- Leave the appliance door open until the oven interior is completely dry.

## Insufficient water

If water needs replenishing during the programme a tone will sound and a reminder to refill the container will appear in the display.

- Remove the water container and fill it with fresh tap water.
- Push the water container into the appliance until it connects.

Operation will continue.

## Interrupting operation

Operation is interrupted as soon as the door is opened. The heating will switch off and the cooking duration remaining stored in memory.



Danger of burning.

Steam can escape when the door is opened.

Step back and wait until the steam has dissipated.



Danger of burning.

You could burn yourself on the oven interior walls, spilled food and hot steam.

Wear oven gloves when placing food in the oven or removing it and when adjusting oven shelves etc. in a hot oven

Operation will resume when the door is closed.

The oven will heat up again and the display will show the temperature of the cooking compartment as it rises.

Once the set temperature has been reached, the display will change to show the cooking duration remaining as it counts down.

The cooking programme will finish early if the door is opened in the last minute of cooking time (55 seconds duration remaining).

# Operation: Steam cooking

---

## Advanced operation

### Setting further durations

You have placed the food in the oven, selected a temperature and a duration.

- Select **Change**.

Further options will appear in the display which you can select or change for your programme:

- Ready at
- Start at
- Change function  
(see "Changing settings during a programme - Changing the function")

You can set the programme to switch on and off automatically by setting **Ready at** or **Start at**.

- Ready at

You specify the time you want cooking to stop.

- Start at

You specify the time you want cooking to start.

Cooking results can be impaired if there is a long delay between the food being placed in the oven and the start of cooking. Fresh food can change colour and even deteriorate.

If the temperature in the oven is too high, e.g. just after another programme, you will not be able to use this function. **Ready at / Start at** will not appear in the display if this is the case. Open the oven door until the appliance has cooled down.

A **Ready at** time cannot be entered if you are using the food probe. When using the food probe, the end of the cooking duration is determined by when the set core temperature is reached. Only **Start at** can be selected.

# Operation: Steam cooking

## Switching on and off automatically

To switch a cooking programme on and off automatically you have a choice of how to enter the time parameters:

- Duration and Ready at
- Duration and Start at

Example: it is 11:45. The food takes 5 minutes to cook and should be ready at 12:30.

- Select Change.
- Select Duration and set a duration of "00:05" h.
- Confirm with OK.
- Select Ready at and set 12:30.
- Confirm with OK.

Start at is calculated automatically. The cooking duration entered is added to the heating-up time calculated by the steam oven.

Start at 12:18 appears in the display. The cooking programme will start automatically at this time.

## Sequence of an automatic programme

**Up until the start** the function, the selected temperature, Start at and the start time will appear in the display.

**After the start time** you can see the temperature increasing in the display during the heating-up phase until the set temperature is reached. Once this temperature is reached a tone will sound.

**After the heating-up phase** you can follow the time counting down in the display. The last minute counts down in seconds.

**At the end of the programme** the steam generator will switch off. A tone or melody will sound (see "Settings - Acoustic tones").

Steam reduction (only with temperatures over approx. 80 °C) and Process finished will appear in the display.

You have the option of saving your settings as a User programme (see "User programmes") or increasing the cooking duration via Change. Touch ↵ to go to the main menu.

## Operation: Steam cooking

---

### Changing settings during a programme

- Select Change.

The following will appear in the display:

- Temperature
- Duration
- Ready at
- Start at

If the temperature in the oven is too high Ready at and Start at are not displayed.

- Change function

### Changing the temperature

- Select Temperature.
- Change the temperature.
- Confirm with OK.

The programme will restart with the new temperature.

You can permanently reset the recommended temperature to suit your own cooking preferences. (See "Settings - Recommended temperatures").

### Changing the cooking duration

- Select Duration.
- Change the duration.
- Confirm with OK.

The programme will restart with the new duration.

### Deleting a finish time

- Select Ready at.
- Select Reset.

The finish time is now deleted.

The programme will start using the duration set.

### Changing the function

- Select Change function.
- Select the function you want.

The new function will appear in the display together with its recommended temperature.

- Change the temperature if necessary.
- Confirm with OK.
- Set a different cooking duration if necessary.
- Confirm with OK.

The function has been changed.

### Cancelling cooking

- Touch ↵.

Cancel cooking? appears in the display.

- Select Yes.

The main menu will appear. Any cooking durations set will be deleted.

## Operation: Combination cooking mode

---

Combi mode works by combining dry heat and steam. You can combine up to ten cooking stages in a combination mode programme. You can set the temperature, grill level, moisture level and duration or core temperature (when using the food probe) for each cooking stage.

The cooking programme will be carried out in the order in which the individual stages are entered.

The following functions are available:

- Fan plus
- Conventional heat
- Full grill

The food probe cannot be used with Full grill.

You cannot cook with a core temperature after a cooking stage using Full grill.

## Operation: Combination cooking mode

---

A malfunction can occur if the drain is blocked.

Before each cooking programme ensure that the filter in the bottom of the cooking compartment is correctly fitted. Otherwise coarse soiling could get into the drainage system and cause a blockage.

### Simple operation

The following example describes a cooking programme with 3 cooking stages.

- Switch the steam oven on using ①.

The main menu appears in the display.

**Only use cold mains tap water** (less than 20 °C). Never use distilled or mineral water or other liquids.

- Fill the water container and push it back in so that it connects.
- Insert the food probe if required into the food (see "Food probe").
- Place the food in the oven.
- When cooking on the rack, insert the universal tray underneath it.
- Select Oven functions.
- Select Combi mode.

### Cooking stage 1

#### Fan plus / Conventional heat

- Set the temperature.
- Confirm with OK.
- Set the required moisture.
- Confirm with OK.
- Select Set the duration or Set core temperature.
- Set the cooking duration or core temperature. Any time between 1 minute and 12 hours can be set.
- Confirm with OK.
- Select Add cooking stage.

#### Full grill

- Set the grill level.
- Confirm with OK.
- Set the required moisture.
- Confirm with OK.
- Set the cooking duration. Any time between 1 minute and 6 hours can be set.
- Confirm with OK.
- Select Add cooking stage.

### Cooking stage 2

- Select the function you want.
- Select the required settings (see cooking stage 1).
- Confirm with OK.
- Select Add cooking stage.

# Operation: Combination cooking mode

## Cooking stage 3

- Select the function you want.
- Select the required settings (see cooking stage 1).
- Confirm with OK.
- Select Finish Combi mode.

A summary of your settings will appear in the display.

- Check the settings and confirm with **Accept** or select **Change** to correct the settings or to add further cooking stages.

When you have confirmed the settings, the following will appear in the display:

- Start now
- Save
- Ready at
- Start at

A Ready at time cannot be entered if you are using the food probe. When using the food probe, the end of the cooking duration is determined by when the set core temperature is reached. Only Start later can be selected.

- Change cooking stages
- If you wish to save your settings as a User programme select **Save** and enter a programme name (see "User programmes").
- Start the programme immediately or alter further settings as necessary (see "Advanced operation").

## At the end of the cooking duration

- Steam reduction (only with temperatures of approx. 80 - 100 °C and 100% moisture) and Process finished will appear in the display.
- the fan remains switched on,
- a tone or melody will sound (see "Settings - Acoustic tones")

You have the option of saving your settings as a User programme (see "User programmes"). Touch  twice to go to the main menu.



**Danger of burning.**

You could burn yourself on the oven interior walls, spilled food and accessories

Use oven gloves when removing hot food from the oven.

- Wait until **Steam reduction** goes out in the display before opening the door and removing the food.

# Operation: Combination cooking mode

## After use

- Remove and empty the water container and condensate container. Push upwards slightly as you take them out of the appliance.
- Switch the steam oven off using ①.

Following a cooking programme with steam Appliance rinsing will appear in the display after the steam oven has been switched off.

This process should be carried out every time to flush any remaining food deposits out of the system.

- Follow the instructions in the display.
- After each use, clean and dry the whole appliance as described in "Cleaning and care".
- Leave the appliance door open until the oven interior is completely dry.

## Insufficient water

If water needs replenishing during the programme a tone will sound and a reminder to refill the container will appear in the display.

- Remove the water container and fill it with fresh tap water.
- Push the water container into the appliance until it connects.

Operation will continue.

## Interrupting operation

Operation is interrupted as soon as the door is opened. The heating will switch off and the cooking duration remaining stored in memory.

 Danger of burning.

Steam can escape when the door is opened.

Step back and wait until the steam has dissipated.

 Danger of burning.

You could burn yourself on the oven interior walls, spilled food and hot steam.

Wear oven gloves when placing food in the oven or removing it and when adjusting oven shelves etc. in a hot oven

Operation will resume when the door is closed.

The oven will heat up again and the display will show the temperature of the cooking compartment as it rises. Once the set temperature has been reached, the display will change to show the cooking duration remaining as it counts down.

For cooking programmes with 100 % moisture and temperatures up to 100 °C:

The cooking programme will finish early if the door is opened in the last minute of cooking time (55 seconds duration remaining).

# Operation: Combination cooking mode

## Advanced operation

### Setting further durations

You have placed the food in the oven and selected the settings for the programme.

You can set the programme to switch on and off automatically by setting Ready at or Start at.

– Ready at

You specify the time you want cooking to stop.

– Start at

You specify the time you want cooking to start.

Cooking results can be impaired if there is a long delay between the food being placed in the oven and the start of cooking. Fresh food can change colour and even deteriorate.

If the temperature in the oven is too high, e.g. just after another programme, you will not be able to use this function. Ready at and Start at will not appear in the display if this is the case. Open the oven door until the appliance has cooled down.

A Ready at time cannot be entered if you are using the food probe. When using the food probe, the end of the cooking duration is determined by when the set core temperature is reached. Only Start later can be selected.

### Switching on and off automatically

To switch a cooking programme on and off automatically you have a choice of how to enter the time parameters:

- Duration and Ready at
- Duration and Start at

Example: it is 11:45. The food takes 5 minutes to cook and should be ready at 12:30.

■ Enter a cooking duration of 5 minutes for the 1st cooking stage (see "Simple operation").

When you have selected the settings for the cooking process:

- Select Ready at and set 12:30.
- Confirm with OK.

Start at is calculated automatically.

Start at 12:25 appears in the display. The cooking programme will start automatically at this time.

# Operation: Combination cooking mode

---

## Sequence of an automatic programme

**Up until the start time** the function, the selected temperature and moisture level, Start at and the start time will appear in the display.

**After the start time** you can see the temperature increasing in the display during the heating-up phase until the set temperature is reached. Once this temperature is reached a tone will sound.

**After the heating-up phase** you can follow the time counting down in the display. The last minute counts down in seconds.

**At the end of the cooking process** the steam generator and oven compartment lighting will switch off. A tone or a melody will sound (see "Settings - Acoustic tones").

Steam reduction (only with temperatures of approx. 80 - 100 °C and 100 % moisture) and Process finished will appear in the display.

You have the option of saving your settings as a User programme (see "User programmes"). Touch ↵ to go to the main menu.

## Changing settings during a programme

- Select Change.

The following will appear in the display:

- all individual cooking stages
- Add cooking stage

You can change the specified settings for a cooking stage or add more cooking stages to the programme.

- Select the cooking stage you want to change or Add cooking stage.
- Alter the cooking stages as you wish (see "Simple operation") and confirm with OK.

A summary of your settings will appear in the display.

- Check the settings and confirm with Accept or select Change to correct the settings or to add further cooking stages.

## Cancelling cooking

- Touch ↵.

Cancel cooking? appears in the display.

- Select Yes.

The list of functions will appear. Any cooking durations set will be deleted.

If you press ↵ again the main menu will appear.

## Operation: Functions without steam

---

You do not necessarily need to enter a cooking duration for functions which do not use steam. If no duration is entered, operation starts automatically as soon as the temperature has been confirmed or after 15 seconds. The steam oven will switch off automatically after a maximum 12 hours of operation, or after a maximum 6 hours for grill functions.

If a cooking duration is entered, it starts to count down when the heating-up phase begins.

You can choose to inject a burst of steam. The steam will be injected as soon as you have selected this option and  will appear in the display. It takes about 1 minute. There is no limit to the number of times you can inject a burst of steam.

The following functions are available:

- Fan plus
- Conventional heat
- Intensive bake
- Bottom heat
- Top heat
- Full grill
- Economy grill
- Fan grill
- Cake plus
- Gentle bake

<p>The food probe cannot be used with Full grill and Economy grill.</p>
-------------------------------------------------------------------------

## Operation: Functions without steam

---

The grease filter on the back wall must be removed for baking as otherwise this can result in uneven browning. Exception: fit the grease filter in the back wall when baking open deep fresh fruit flans, e.g. plum or damson or pizza with lots of topping.

The recommended temperature will be automatically accepted within a few seconds.  
If required, select **Change | Temperature** to go back to the temperature selection option.

The cooking programme will start. The oven heating, lighting and fan will switch on.

### Simple operation

- Remove the grease filter from the back panel.
- Switch the steam oven on using ①.

The main menu appears in the display.

- If you wish to cook with bursts of steam, fill the water container and push it back in so that it connects.
- Insert the food probe if required into the food (see "Food probe").
- Place the food in the oven.
- Select **Oven functions**.
- Select the function you want.
- Change the recommended / core temperature or grill level if necessary.
- Confirm with **OK**.

- Set further settings as necessary, e.g. setting a cooking duration (see "Advanced operation").

# Operation: Functions without steam

## After cooking



Danger of burning.

You could burn yourself on the oven interior walls, spilled food and accessories

Use oven gloves when removing hot food from the oven.

- Take the food out of the oven.
- Switch the steam oven off using ①.
- After each use, clean and dry the whole appliance as described in "Cleaning and care".
- Leave the appliance door open until the oven interior is completely dry.

## Interrupting operation

Operation is interrupted as soon as the door is opened. The heating will be switched off.



Danger of burning.

You could burn yourself on the oven interior walls, spilled food and accessories.

Wear oven gloves when placing food in the oven or removing it and when adjusting oven shelves etc. in a hot oven

Operation will resume when the door is closed.

The steam oven will heat up again and the display will show the temperature in the oven compartment as it rises.

# Operation: Functions without steam

---

## Advanced operation

You have placed the food in the oven, selected a function and set the temperature or grill level.

### ■ Select Change.

Further options will appear in the display which you can select or change for your programme:

- Duration
- Ready at

A Duration and Ready at time cannot be entered if you are using the food probe. When using the food probe, the end of the cooking duration is determined by when the set core temperature is reached.

- Start at  
Only appears when either Duration or Ready at have been set or if you are using the food probe.
- Heating-up phase  
Only appears if you have set a temperature of more than 100 °C in Fan plus and Conventional heat.
- Change function

## Setting further durations

By entering Duration, Ready at or Start at you can automatically switch the cooking programme off or on and off.

- Duration

Enter the cooking duration required. You can select a duration of between 1 minute and 12 hours, or 1 minute 6 hours for grill functions.

- Ready at

You specify the time you want cooking to stop.

- Start at

You specify the time you want cooking to start.

When baking, the oven should not be set to start a long time off. Otherwise the cake mixture or dough will dry out, and the raising agents will lose their effectiveness.

Cooking results can be impaired if there is a long delay between the food being placed in the oven and the start of cooking. Fresh food can change colour and even deteriorate.

# Operation: Functions without steam

## Switching off automatically

To switch off a programme automatically you can set either Duration or Ready at.

Example: it is 11:45. The food takes 30 minutes to cook and should be ready at 12:15.

- Select Change.
- Select Duration and set "00:30".
- Confirm with OK.

or

- Select Change.
- Select Ready at and set 12:15.
- Confirm with OK.

The oven will switch off automatically after this duration has elapsed or the time set has been reached.

## Switching on and off automatically

We recommend switching on and off automatically when roasting.

To switch a cooking programme on and off automatically you have a choice of how to enter the time parameters:

- Duration and Ready at
- Duration and Start at
- Ready at and Start at

Example: it is 11:30. The food takes 30 minutes to cook and should be ready at 12:30.

- Select Change.
- Select Duration and set "00:30" h.
- Confirm with OK.
- Select Ready at and set 12:30.
- Confirm with OK.

Start at is calculated automatically.

Start at 12:00 appears in the display. The cooking process will start automatically at this time.

## Operation: Functions without steam

---

### Sequence of an automatic programme

**Up until the start** the function, the selected temperature, *Start at* and the start time will appear in the display.

**After the start time** you can see the temperature increasing in the display during the heating-up phase until the set temperature is reached. Once this temperature is reached a tone will sound.

**After the heating-up phase** you can follow the time counting down in the display. The last minute counts down in seconds.

**At the end of the programme** the oven compartment heating will switch off. A tone or melody will sound (see "Settings - Acoustic tones").

Process finished will appear in the display.

You have the option of saving your settings as a User programme (see "User programmes") or increasing the cooking duration via *Change*. Touch ↩ to go to the main menu.

### Rapid heat-up

Rapid heat-up can be used to speed up the heating up phase.

This function switches on automatically if you set the temperature above 100 °C for Fan plus and Conventional heat.

Rapid heat-up should be switched off when cooking pizza and delicate items (e.g. sponge or biscuits). These will get brown too quickly on the top.

You can switch off Rapid heat-up for a relevant cooking process via the Heating-up phase option.

#### Heating-up phase **Option**

##### – Rapid

The top heat/grill element and the ring heating element come on together with the fan to enable the steam oven to reach the required temperature as quickly as possible.

##### – Normal

Only the heating elements for the oven function selected are switched on.

# Operation: Functions without steam

## Switching off Rapid heat-up

- Select Change.
- Select Heating-up phase.
- Select Normal.
- Confirm with OK.

Rapid heat-up has been switched off.  
Heating-up phase appears in the display.

## Changing the function

You can change the cooking function during operation.

- Select Change.
- Select Change function.
- Select the function you want.

The new function will appear in the display together with its recommended temperature.

- Change the temperature if necessary.
- Confirm with OK.

Any cooking durations set will be adopted. Exception: If you change to Combi mode, Steam cooking or Sous-vide, you must enter a new duration.

- Change the cooking duration if necessary.
- Confirm with OK.

The function has been changed.

## Changing settings during a programme

- Select Change.

The following will appear in the display:

- Temperature or Grill setting
- Duration
- Core temp.

This option only appears when you are using the food probe.

- Ready at

A Duration and Ready at time cannot be entered if you are using the food probe. When using the food probe, the end of the cooking duration is determined by when the set core temperature is reached.

- Start at

Only appears if you have set Duration or Ready at or when using the food probe.

- Heating-up phase

Only appears if you have set a temperature of more than 100 °C in Fan plus and Conventional heat.

- Change function

## Operation: Functions without steam

---

### Changing the temperature

- Select Temperature.
- Change the temperature.
- Confirm with OK.

The steam oven will be heated up or cooled down until the altered temperature is reached.

You can also permanently reset the recommended temperature to suit your cooking preferences. See "Settings - Recommended temperatures".

### Changing the core temperature

- Select Core temp..
- Change the core temperature.
- Confirm with OK.

### Changing the grill level

- Select Grill setting.
- Change the level.
- Confirm with OK.

The programme will restart with the new grill level.

### Changing the cooking duration

- Select Duration.
- Change the duration.
- Confirm with OK.

The programme will restart with the new duration.

### Deleting a cooking duration

- Select Duration.
- Select Reset.

The programme will continue with the set temperature.

### Deleting a finish time

- Select Ready at.
- Select Reset.

The finish time is now deleted.

The programme will start using the duration set.

### Cancelling cooking

- If you have not set a cooking duration touch ↵.

The main menu will appear.

- If you have set a cooking duration or are using the food probe touch ↵.

Cancel cooking? appears in the display.

- Select Yes.

The main menu will appear. Any cooking durations or core temperature set will be deleted.

Your steam oven has a wide range of Automatic programmes to enable you to achieve excellent results with ease. Simply select the appropriate programme for the type of food you are cooking and follow the instructions in the display.

### List of food types

Automatic programmes are accessed via Automatic progs..

- Vegetables
- Fish
- Meat
- Bread
- Rolls
- Cakes/biscuits
- Pizza, Quiche & Co.
- Rice
- Grain
- Pasta
- Pulses
- Hen's eggs
- Fruit
- Mushrooms
- Sausages
- Shellfish
- Mussels
- Special

# Automatic programmes

---

## To use an Automatic programme

- Select Automatic progs.

A list of food types will appear in the display.

- Select the food category.

The Automatic programmes available for the food type selected will then appear.

- Select the Automatic programme that you want.

Each step you need to take before starting the Automatic programme will appear in the display.

In some programmes you will be prompted on when to add food to the oven. Follow and confirm these instructions.

## Notes on using these programmes

- The degree of doneness and browning levels are shown in a bar chart with seven segments. The factory default is always the middle setting. It will be highlighted. To change the setting simply move the highlighting to the left or the right.
- The weight entry in the Automatic programmes refers to the weight per piece. For example, you can cook just one piece of salmon weighing 250 g or 10 pieces of salmon weighing 250 g at the same time.
- The oven interior needs to be at room temperature before starting an Automatic programme.

- When placing food in an already hot steam oven, be very careful when opening the door. Hot steam can escape. Step back from the steam oven and wait until the steam has dissipated. When putting cooking containers or the condensate tray into the oven or taking them out, take care not to spill the contents. Avoid contact with hot steam, and do not touch the hot oven interior walls. Danger of burning and scalding.
- Please refer to the cookbook for information on suitable baking containers.
- For some Automatic programmes the start time can be delayed using Start at or Ready at.
- To end an automatic programme early, you need to switch the steam oven off completely by touching ↵.

Cancel cooking? will appear in the display. If Yes is selected, the main menu will be shown in the display.

- If by the end of an Automatic programme the food is not cooked enough, select Cont. cooking or Continue baking.
- Automatic programmes can also be saved as User programmes.

You can create and save up to 20 of your own programmes.

- Each one can have up to 10 cooking stages. This enables you to save your favourite or most frequently used recipes very accurately. You can save individual settings for each stage.
- You can enter the name of the programme for your recipe.

When you next select the programme it will start automatically.

There are different ways of creating a User programme:

- At the end of an Automatic programme, save it as a User programme.
- After running a programme with a set duration, save it.

Then name the programme.

## To create a User programme

- Select User programmes.

If you have not yet created a User programme **Create programme** will appear in the display.

- Confirm with OK.

If User programmes already exist, the programme names will appear with **Edit programmes** underneath them.

- Select **Edit programmes**.

- Select **Create programme**.

You can now specify the settings for cooking stage 1.

Follow the instructions in the display:

- Select and confirm the cooking function, temperature, grill level and if necessary moisture level and duration or core temperature.

With **Fan plus** and **Conventional** heat you can specify whether you wish to use **Rapid heat-up** for this cooking stage via **Further parameters** (see "Operation: Functions without steam - Rapid heat-up").

Settings for the 1st cooking stage have now been set.

You can add more cooking stages, for example, if you want to add another cooking function to follow on from the first:

- Select **Add cooking stage** and proceed as for the 1st cooking stage.
- When you have finished setting all the cooking stages select **Finish programme**.

## User programmes

---

A summary of your settings will appear in the display.

- Check the settings and confirm with **Accept** or select **Change** to correct the settings or to add further cooking stages.
- Select **Save**.
- Enter the programme name.

The following symbols will appear next to the alphabet:

Symb ol	Meaning
␣	Space
ABC	Alphabet in upper case
abc	Alphabet in lower case
123	Numerals 0 to 9 and hyphen

- Touch the sensors next to the symbols to highlight the character you want.
- Select **Select**.

The letter or number you have selected will appear in the top line of the display.

A maximum of 10 characters can be used.

You can delete the characters one at a time with ↵.

- Select the rest of the letters or numbers for your programme name.
- Once you have entered the programme name, select **Save**.

A message will appear in the display confirming that the programme has been saved.

- Confirm with **OK**.

You can start the saved programme immediately, delay the start or change the cooking stages.

The option **Change cooking stages** is described in "To change a User programme".

## To start a User programme

- Place the food in the oven.
- Select User programmes.

The programme names will appear with Edit programmes underneath them in the display.

- Select the programme you want.

You can start the saved programme immediately, delay the start or change the cooking stages.

- Start now

The programme will start. The oven compartment lighting and the steam generator will switch on immediately.

- Start later

This option only appears if you are using the food probe. You can specify when you want the programme to start.

- Ready at

You specify the time you want cooking to stop.

- Start at

You specify the time you want cooking to start.

- Change cooking stages

You can change the specified settings for a cooking stage or add more cooking stages to the programme (see "To change a User programme").

- Select the function you want.

The programme will start according to the specified start or finish time.

## To change a User programme

### Changing cooking stages

Cooking stages in an Automatic programme that you have renamed as a User programme cannot be changed.

- Select User programmes.

The programme names will appear with Edit programmes underneath them in the display.

- Select Edit programmes.

- Select Change programme.

- Select the programme you want.

- Select Change cooking stages.

You can change the specified settings for a cooking stage or add more cooking stages to the programme.

- Select the cooking stage you want to change or Add cooking stage.

- Change the programme as you wish (see "To create a User programme") and confirm with OK.

A summary of your settings will appear in the display.

- Check the settings and then select Save.

The additional stages or changes to your programme will be saved.

- Change the name if necessary (see "To create a User programme").

# User programmes

---

## Changing the name

- Select User programmes.

The programme names will appear with Edit programmes underneath them in the display.

- Select Edit programmes.
- Select Change programme.
- Select the programme you want.
- Select Change name.
- Change the name (see "To create a User programme") and select Save.

A message will appear in the display confirming that the programme has been saved.

- Confirm with OK.

## To delete a User programme

- Select User programmes.

The programme names will appear in the display and Edit programmes underneath.

- Select Edit programmes.
- Select Delete programme.
- Select the programme you want.
- If you wish to delete the programme confirm with Yes.

The programme is deleted.

You can delete all User programmes at once (see "Settings - Factory default - User programmes").

The minute minder can be used to time other activities in the kitchen, e.g. boiling eggs.

The minute minder can also be used at the same time as a cooking programme in which the start and finish times have been set, e.g. as a reminder to stir a dish or add seasoning etc.

A maximum minute minder duration of 9 hours, 59 minutes and 59 seconds can be set.

## To set the minute minder

If you want to use the minute minder and Time | Show | Off has been set, you will need to switch the steam oven on before you can set the minute minder. The minute minder can then be seen counting down in the display when the steam oven is switched off.

Example: You want to boil some eggs and set a minute minder duration of 6 minutes and 20 seconds.

- Touch .



0:00:00 will appear  
(h:min:sec).

- Use the numerical keypad to enter a different duration (6-2-0).
- Confirm with OK.

The duration counts down in the display when the oven is switched off.

If a cooking programme is being run at the same time the minute minder duration will appear in the bottom of the display.

## At the end of the minute minder duration

-  will flash in the display,
- the display will show the time counting upwards,
- a tone or melody will sound (see "Settings - Acoustic information")
- Touch  or the illuminated sensor next to the minute minder to switch off the acoustic and optical signals.

## To change the duration set for the minute minder

- Touch  or the illuminated sensor next to the minute minder duration which is counting down.

The minute minder duration selected appears in the display.

- Use the numerical keypad to enter a different minute minder duration.
- Confirm with OK.

The altered minute minder duration will start to count down immediately.

## To cancel the duration set for the minute minder

- Touch  or the illuminated sensor next to the minute minder duration which is counting down.

The minute minder duration selected appears in the display.

- Select **Reset**.

The minute minder duration is now cancelled.

# General notes

---

This section contains general information. You will find more detailed information about particular foods and how to cook them in the other sections.

## The advantages of cooking with steam

Almost all vitamins and minerals are retained as the food is not immersed in water.

Cooking with steam also retains the true taste of the food better than conventional cooking. We therefore recommend seasoning the food after it has been cooked. Food also retains its fresh, original colour.

## Suitable containers

### Cooking containers

This steam oven is supplied with stainless steel cooking containers. Other containers, in a variety of sizes, both perforated and solid, are available as optional extras (see "Optional accessories"). This enables you to choose the most suitable container for the food you are cooking.

It is best to use perforated containers for **steam cooking**. The steam can reach the food from all sides and the food is cooked evenly.

## Your own containers

You can also use your own containers. However, please note the following:

- The container must be suitable for using in an oven and must be steam resistant. Plastic containers can only be used for steam cooking if the manufacturer has stated that they are suitable for such use.
- Thick-sided containers made from porcelain, china or stoneware, for example, are not so suitable for steam cooking. They do not conduct heat well and as a result cooking durations will be considerably longer than those given in the charts.
- Place the cooking containers on the rack or in a suitable container, and not on the oven floor.
- Ensure that there is a gap between the upper rim of the container and the top of the cooking compartment to allow sufficient steam into the container.

## Shelf level

You can select any shelf level. You can also cook on several levels at the same time. This will not alter the cooking duration.

When using more than one deep container at the same time for steam cooking it is best to offset them on their runners and to leave at least one level free in between them.

Always insert cooking containers, the rack and the tray between the rails of the side runners so that they cannot tip.

## Frozen food

The heating up phase for frozen food is longer than for fresh food. The greater the quantity of frozen food, the longer the heating up phase.

## Temperature

A maximum temperature of 100 °C is reached when steam cooking is taking place. Most types of food will cook at this temperature. Some more delicate types of food, such as soft fruit, must be cooked at lower temperatures as otherwise they will burst. More information is given in the relevant section.

### Combination with a warming drawer

When the warming drawer is in use the oven cavity in the steam oven can get up to 40 °C. If, in this case, you set a temperature of 40 °C (Steam cooking) or 30–40 °C and 100 % moisture (Combination cooking), steam will not be produced because the oven cavity is too warm.

## Duration

In general, the cooking durations for cooking with steam are the same as for cooking food in a saucepan. More information about any factors which may affect the cooking duration is given in the relevant sections.

The quantity of food does not affect the cooking duration. 1 kg of potatoes will take the same time to cook as 500 g.

The durations given in the charts are guidelines only. We recommend selecting the shorter cooking duration quoted to start with. If food is not cooked sufficiently after the shorter time it can be put back in the oven and cooked for longer.

## Cooking with liquid

When cooking with liquid only fill the cooking container  $\frac{2}{3}$  full to prevent the liquid spilling when the cooking container is removed from the oven.

## Your own recipes - steam cooking

Food and recipes which are prepared in pot or a pan can also be cooked in the steam oven. The cooking times in the steam oven will be the same. Please note that food will not be brown or crisp when cooking with steam.

## General notes

---

### **Combi rack / Universal tray**

Use the rack above the universal tray when roasting or grilling. The meat juices will collect in the tray and can then be used to make a gravy or sauce.

If you are using the universal tray with the rack on top, e.g. for grilling, insert the tray between the rails of the side runners and the rack will automatically slide in above them. When removing them from the oven pull both out together.

### **Non-tip safety notches**

The combi rack and universal tray have non-tip safety notches which prevent them being pulled right out when they only need to be partially pulled out. The tray and rack can then only be taken out of the oven by raising them upwards and then pulling them out.

## Vegetables

### Fresh

Prepare fresh vegetables in the usual way, i.e. wash, clean and cut them up.

### Frozen

Frozen vegetables do not need to be defrosted beforehand, unless they have been frozen together in a block.

Frozen and fresh vegetables which take the same length of time to cook can be cooked together.

Break up vegetables that have frozen together in a lump and follow instructions on the packaging regarding cooking duration.

### Cooking containers

Food such as peas or asparagus spears, which have little or no space between them, will take longer to cook because the steam has less space to work in. For an even result, it is best to use a shallow container for these types of food, and only fill it about 3-5 cm deep. When cooking large quantities divide the food between 2 or 3 shallow containers rather than using one deep one.

Different types of vegetables which take the same length of time to cook can be cooked together.

Use solid containers for vegetables which are cooked in liquid.

### Shelf level

To avoid any colour transfer when cooking vegetables with a distinctive colour (e.g. beetroot) in a perforated container, do not place other food underneath the perforated container.

### Duration

As with conventional methods, the cooking duration when cooking vegetables with steam will depend on the size and how well done you want them. Example:

firm potatoes, cut into quarters

= approx. 17 minutes

firm potatoes, cut in half

= approx. 21 minutes

### Settings

Automatic programmes | Vegetables | ... |  
Steam cooking

or

Oven functions | Steam cooking

Temperature: 100 °C

Duration: see chart

## Steam cooking

The durations given in the chart are guidelines for fresh vegetables. We recommend selecting the shorter cooking duration quoted. If food is not cooked sufficiently after the shorter duration it can be put back in the oven and cooked for longer.

Vegetables	🕒 [min]
Artichokes	32–38
Cauliflower, whole	27–28
Cauliflower, florets	8
Beans, green	10–12
Broccoli, florets	3–4
Chantenay carrots, whole	7–8
Chantenay carrots, halved	6–7
Chantenay carrots, chopped	4
Chicory, halved	4–5
Chinese cabbage, chopped	3
Peas	3
Fennel, halved	10–12
Fennel, cut into strips	4–5
Curly kale, chopped	23–26
Firm potatoes, peeled whole	27–29
halved	21–22
quartered	16–18
Fairly firm potatoes, peeled whole	25–27
halved	19–21
quartered	17–18
Floury potatoes, peeled whole	26–28
halved	19–20
quartered	15–16
Kohlrabi, cut into batons	6–7

## Steam cooking

<b>Vegetables</b>	 [min]
Pumpkin, diced	2–4
Corn on the cob	30–35
Chard, chopped	2–3
Peppers, diced / cut into strips	2
New potatoes, firm	30–32
Mushrooms	2
Leeks, sliced	4–5
Leeks, halved lengthwise	6
Romanesco, whole	22–25
Romanesco, florets	5–7
Brussels sprouts	10–12
Beetroot, whole	53–57
Red cabbage, chopped	23–26
Black salsify, whole	9–10
Celeriac, cut into batons	6–7
Green asparagus	7
White asparagus	9–10
Main crop carrots, chopped	6
Spinach	1–2
Spring cabbage, chopped	10–11
Celery, chopped	4–5
Swede, chopped	6–7
White cabbage, chopped	12
Savoy cabbage, chopped	10–11
Courgettes, sliced	2–3
Sugar snap peas	5–7

 Duration

# Steam cooking

---

## Meat

### Fresh

Prepare the meat in the usual way.

### Frozen

Meat should be thoroughly defrosted before cooking in the steam oven (see "Defrosting").

### Preparation

For meat which needs to be seared before being cooked, e.g. for a stew, sear the meat in a pan on the hob first.

### Duration

The cooking duration depends on the thickness and the texture of the meat, and not on the weight. The thicker the piece of meat, the longer the cooking duration. A piece of meat weighing 500 g which is 10 cm thick will take longer to cook than a piece of meat weighing 500 g which is 5 cm thick.

## Tips

- Use a perforated container if you wish to retain the **juices** when cooking meat. Place a solid container or the universal tray underneath to catch the juices. You can use these to make a gravy or freeze them for later use.
- Boiling fowl, back or top rib and meat bones can be used to make **stock**. Place the meat together with some mixed vegetables in a solid cooking container and add cold water and cook. The longer the cooking duration, the stronger the stock.

## Settings

Automatic programmes | Meat | ... | Steam cooking

or

Oven functions | Steam cooking

Temperature: 100 °C

Duration: see chart

## Steam cooking

The durations given in the charts are guidelines only. We recommend selecting the shorter cooking duration quoted to start with. If food is not cooked sufficiently after the shorter time it can be put back in the oven and cooked for longer.

Meat	🕒 [min]
Leg steak, covered with water	110–120
Knuckle	135–140
Chicken breast	8–10
Shank	105–115
Top rib, covered with water	110–120
Veal cutlets	3–4
Gammon slices	6–8
Lamb stew	12–16
Poularde	60–70
Turkey roulade	12–15
Turkey escalope	4–6
Brisket, covered with water	130–140
Beef stew	105–115
Boiling fowl, covered with water	80–90
Boiled topside	110–120

🕒 Duration

# Steam cooking

---

## Sausages

### Settings

Automatic programmes | Sausages | ... |  
Steam cooking

or

Oven functions | Steam cooking

Temperature: 90 °C

Duration: see chart

Sausages	🕒 [min]
Frankfurters	6–8
Bologna sausages	6–8
Veal sausages	6–8

🕒 Duration

## Fish

### Fresh

Prepare fresh fish in the usual way, i.e. clean, gut and fillet.

### Frozen food

Fish does not need to be fully defrosted before cooking. Defrost so that the surface is sufficiently thawed to take herbs and seasoning. Depending on the thickness of the fish, 2 - 5 minutes should be enough.

### Preparation

Add some lemon or lime juice to fish before cooking. The citric acid helps the flesh stay firm.

It is not necessary to season fish with salt when cooking with steam as this method retains the minerals which give the fish its unique flavour.

### Cooking containers

If using a perforated container, grease it first.

### Shelf level

When cooking fish in a perforated container at the same time as cooking other types of food in other containers, place the container with the fish directly above the condensate tray/universal tray (depending on model) to catch any liquid and so avoid any transfer of tastes to other food.

## Temperature

### 85 °C – 90 °C

For gently cooking delicate types of fish, such as sole.

### 100 °C

For cooking firmer types of fish, e.g. cod and salmon.

Also for cooking fish in sauce or stock.

## Duration

The cooking duration depends on the thickness and the texture of the fish, and not on the weight. The thicker the fish, the longer the cooking duration. A 3 cm thick piece of fish weighing 500 g will take longer to cook than a 2 cm thick piece of fish weighing 500 g.

The longer fish cooks, the firmer its flesh will become. Use the cooking durations given in the chart. If you find that the fish is not cooked sufficiently only cook it for a few minutes more.

When cooking fish in sauce or stock, we recommend that you increase the cooking duration quoted by a few minutes.

## Tips

- Adding herbs and spices, such as dill, will help bring out the full flavour of the fish.
- Cook large fish in the swimming position. To help maintain the shape of the fish, place a small cup or similar upside down in the cooking container, and arrange the fish bellyside down over the cup.

- You can use any fish scraps, e.g. fish heads, bones, tails etc to make a **fish stock**. Place the fish scraps together with some mixed vegetables in a solid cooking container and add cold water. Cook at 100 °C for 60 to 90 minutes. The longer the cooking duration, the stronger the stock.
- **Blue fish** is fish which is cooked in water and vinegar. It is important not to damage the skin of the fish. This method is suitable for cooking carp, trout, tench, eel and salmon. (Follow recipe instructions for the ratio of water to vinegar).

## Settings

Automatic programmes | Fish | ... | Steam cooking

or

Oven functions | Steam cooking

Temperature: see chart

Duration: see chart

## Steam cooking

The cooking durations given in the chart are guidelines for fresh fish. We recommend selecting the shorter cooking duration quoted. If food is not cooked sufficiently after the shorter duration it can be put back in the oven and cooked for longer.

Fish	🌡️ [°C]	🕒 [min]
Eel	100	5–7
Perch fillet	100	8–10
Seabream fillet	85	3
Trout, 250 g	90	10–13
Halibut fillet	85	4–6
Atlantic cod fillet	100	6
Carp, 1.5 kg	100	18–25
Salmon fillet	100	6–8
Salmon steak	100	8–10
Salmon trout	90	14–17
Coley fillet	85	3
Rose fish fillet	100	6–8
Haddock fillet	100	4–6
Plaice fillet	85	4–5
Monk fish fillet	85	8–10
Sole fillet	85	3
Turbot fillet	85	5–8
Tuna fillet	85	5–10
Pikeperch fillet	85	4

🌡️ Temperature / 🕒 Duration

## Shellfish

### Preparation

Defrost frozen shellfish before cooking with steam.

Peel, remove and discard the intestines, and then wash the shellfish.

### Cooking containers

If using a perforated container, grease it first.

### Duration

The longer shellfish are cooked, the tougher they become. Use the cooking durations given in the chart.

When cooking shellfish in sauce or stock, we recommend that you increase the cooking duration quoted by a few minutes.

### Settings



Automatic programmes | Shellfish | ... | Steam cooking

or

Oven functions | Steam cooking

Temperature: see chart

Duration: see chart

	 [°C]	 [min]
Crevettes	90	3
Prawns	90	3
King prawns	90	4
Small shrimps	90	3
Lobster	95	10–15
Large shrimps	90	3

 Temperature /  Duration

# Steam cooking

---

## Mussels

### Fresh



Warning - danger of food poisoning

Only cook mussels which are closed. Do not eat mussels which have not opened after being cooked.

Steep fresh mussels in water for a few hours before cooking to rinse out any sand. Then scrub the mussels thoroughly to clean them.

### Frozen food

Defrost frozen mussels before cooking.

### Duration

The longer mussels are cooked, the tougher they become. Use the cooking durations given in the chart.

### Settings



Automatic programmes | Mussels | ... | Steam cooking

or

Oven functions | Steam cooking

Temperature: see chart

Duration: see chart

	 [°C]	 [min]
Barnacles	100	2
Cockles	100	2
Bearded mussels	90	12
Scallops	90	5
Razor clams	100	2–4
Venus mussels	90	4

 Temperature /  Duration

## Rice

Rice swells when cooked and needs to be cooked in liquid. The proportion of rice to liquid will vary depending on the type of rice.

The rice absorbs all the liquid and so none of the nutrients are lost.

## Settings

Automatic programmes | Rice | ... | Steam cooking

or

Oven functions | Steam cooking

Temperature: 100 °C

Duration: see chart

	<b>Ratio Rice : Liquid</b>	<b>🕒 [min]</b>
Basmati rice	1 : 1.5	15
Parboiled rice	1 : 1.5	23–25
Round grain rice		
Pudding rice	1 : 2.5	30
Risotto rice	1 : 2.5	18–19
Brown rice	1 : 1.5	26–29
Wild rice	1 : 1.5	26–29

🕒 Duration

# Steam cooking

---

## Pasta

### Dry pasta

Dry pasta swells when it is cooked and needs to be cooked in liquid. The liquid must cover the pasta. Using hot liquid gives better results.

Increase the cooking time stated by the manufacturer by approx.  $\frac{1}{3}$ .

### Fresh

Fresh pasta, such as you can buy from the supermarket chilled counter, does not need to absorb water. Cook fresh pasta in a greased perforated container.

Separate any pieces of pasta which have stuck together and spread them out in the cooking container.

### Settings

Automatic programmes | Pasta | ... | Steam cooking

or

Oven functions | Steam cooking

Temperature: 100 °C

Duration: see chart

<b>Fresh</b>	<b>🕒 [min]</b>
Gnocchi	2
Knöpfli	1
Ravioli	2
Spätzle	1
Tortellini	2
<b>Dry pasta, covered with water</b>	
Tagliatelli	14
Vermicelli	8

🕒 Duration

## Dumplings

Ready made boil-in-the-bag dumplings need to be well covered with water as otherwise they can fall apart. This is because even though they have been soaked in water beforehand they will not absorb enough moisture.

Cook fresh dumplings in a greased, perforated container.

### Settings

Automatic programmes | Pasta | ... | Steam cooking

or

Oven functions | Steam cooking

Temperature: 100 °C

Duration: see chart

	 [min]
Sweet dumplings	30
Yeast dumplings	20
Boil-in-the-bag potato dumplings	20
Boil-in-the-bag bread dumplings	18–20

 Duration

# Steam cooking

---

## Grain

Grain swells during cooking and needs to be cooked in liquid. The proportion of grain to liquid depends on the type of grain.

Grain can be cooked whole or cracked.

## Settings

Automatic programmes | Grain | ... | Steam cooking

or

Oven functions | Steam cooking

Temperature: 100 °C

Duration: see chart

	Ratio Grain : Liquid	🕒 [min]
Amaranth	1 : 1.5	15–17
Bulgur	1 : 1.5	9
Green spelt, whole	1 : 1	18–20
Green spelt, cracked	1 : 1	7
Oats, whole	1 : 1	18
Oats, cracked	1 : 1	7
Millet	1 : 1.5	10
Polenta	1 : 3	10
Quinoa	1 : 1.5	15
Rye, whole	1 : 1	35
Rye, cracked	1 : 1	10
Wheat, whole	1 : 1	30
Wheat, cracked	1 : 1	8

🕒 Duration

## Dried pulses

Soak pulses for at least 10 hours in cold water before cooking. Soaking makes the pulses more digestible and shortens the cooking duration required. Soaked pulses must be covered with liquid during cooking.

**Lentils** do not need to be soaked before cooking.

With unsoaked pulses a certain ratio of pulses to liquid is required depending on variety.

## Settings

Automatic programmes | Pulses | ... | Steam cooking

or

Oven functions | Steam cooking

Temperature: 100 °C

Duration: see chart

Soaked	
	🕒 [min]
<b>Beans</b>	
Kidney beans	55–65
Adzuki beans	20–25
Black beans	55–60
Pinto beans	55–65
Haricot beans	34–36
<b>Peas</b>	
Yellow split peas	40–50
Green split peas	27

🕒 Duration

# Steam cooking

Unsoaked		
	Ratio Pulses : Liquid	🕒 [min]
<b>Beans</b>		
Kidney beans	1 : 3	130–140
Adzuki beans	1 : 3	95–105
Black beans	1 : 3	100–120
Pinto beans	1 : 3	115–135
Haricot beans	1 : 3	80–90
<b>Lentils</b>		
Brown lentils	1 : 2	13–14
Red lentils	1 : 2	7
<b>Peas</b>		
Yellow split peas	1 : 3	110–130
Green split peas	1 : 3	60–70

🕒 Duration

## Hen's eggs

Use a perforated container to boil eggs in the steam oven.

The eggs do not need to be pierced before cooking as they are gradually warmed during the heating up phase and so do not burst when they are cooked with steam.

When using a solid container for making egg dishes such as scrambled eggs, remember to grease it first.

## Settings

Automatic programmes | Hen's eggs | ... | Steam cooking

or

Oven functions | Steam cooking

Temperature: 100 °C

Duration: see chart

	 [min]
<b>Small</b> soft medium hard	3 5 9
<b>Medium</b> soft medium hard	4 6 10
<b>Large</b> soft medium hard	5 6–7 12
<b>Extra large</b> soft medium hard	6 8 13

 Duration

# Steam cooking

---

## Fruit

Cook fruit in a solid container so that none of the juice is lost. If you wish to cook fruit in a perforated container, place a solid container directly underneath it to collect the juice.

**Tip:** You can use the juice which has collected in the solid container to make a glaze for a fruit flan.

## Settings

Automatic programmes | Fruit | ... | Steam cooking

or

Oven functions | Steam cooking

Temperature: 100 °C

Duration: see chart

	 [min]
Apple pieces	1–3
Pear chunks	1–3
Cherries	2–4
Mirabelle plums	1–2
Nectarine / Peach pieces	1–2
Plums	1–3
Quince, diced	6–8
Rhubarb pieces	1–2
Gooseberries	2–3

 Duration

## Menu cooking (cooking whole meals) - manually

Before cooking meals with the Menu cooking function switch off the steam reduction system (see "Settings - Steam reduction").

You can use the steam oven to cook a whole meal containing types of food which have different cooking durations, e.g. fish fillet with rice and broccoli. Each dish is placed in the oven at different times so that they are all ready at the same time.

### Shelf level

When cooking fish or food with a distinctive colour (e.g. beetroot) in a perforated container, place the perforated container directly above the condensate tray / universal tray (depending on model) to avoid any transfer of flavour or colour to other food and to prevent liquid dripping onto food below it.

### Temperature

Whole meals should be cooked at a temperature of 100 °C as this is the temperature required to cook the majority of foods.

Do not cook a whole meal at the lowest temperature when different temperatures are required for different types of food, e.g. 85 °C for seabream and 100 °C for potatoes.

If the recommended cooking temperature for the food is 85 °C for example, try cooking it at 100 °C and testing the result. Some delicate types

of fish with a soft structure, e.g. sole and plaice will become very firm when cooked at 100 °C.

### Duration

If you are increasing the recommended temperature, shorten the cooking duration by approx.  $\frac{1}{3}$ .

### Example

Rice	20 minutes
Rose fish fillet	6 minutes
Broccoli	4 minutes

20 minutes minus 6 minutes =  
14 minutes (1st duration: rice)

6 minutes minus 4 minutes = 2 minutes  
(2nd duration: rose fish fillet)

Remaining time = 4 minutes  
(3rd duration: broccoli)

Durations	20 min. - rice		
		6 min. - fish fillet	
			4 min. - broccoli
Setting	14 min	2 min.	4 min.

# Steam cooking

---

## Procedure

- Place the rice in the oven first.
- Set the first cooking duration: 14 minutes.
- After 14 minutes, place the fish in the steam oven.
- Set the second cooking duration: 2 minutes.
- After 2 minutes, place the broccoli in the steam oven.
- Set the third cooking duration: 4 minutes.

## Sous-vide (vacuum) cooking

---

With this gentle cooking method, food is cooked slowly and at a low, constant temperature in vacuum packaging.

With vacuum cooking, no moisture evaporates during cooking and all nutrients and flavours are retained.

The cooking result has an intensive taste and food is cooked evenly.

Use only fresh food which is in a good condition.

Ensure hygienic conditions and that food has not been out of the refrigerator too long, e.g. during transportation.

Use only heat-stable, boiling-resistant vacuum sealing bags.

Do not cook food in the sales packaging, such as vacuum-packed frozen food as it is possible that the packaging used is not suitable for vacuum cooking.

Do not use the vacuum sealing bag more than once.

Vacuum-seal the food in a chamber system vacuum sealer only.

# Sous-vide (vacuum) cooking

---

## Important

For an optimum cooking result:

- Use fewer herbs and spices than for conventional cooking as the effect on the taste of the food is more intensive.

You can also prepare the food without seasoning and add seasoning after cooking.

- The cooking duration is reduced when salt, sugar, and liquids are added.
- The food becomes firmer if acidic ingredients, such as lemon or vinegar are added.
- Do not use alcohol or garlic as this can cause an unpleasant taste.
- Only use vacuum sealing bags that match the size of the food. If the bag is too big, too much air may remain inside.
- If you want to cook several items of food in one vacuum sealing bag, put them side-by-side in the bag.
- If you want to cook food in several bags at once, put the bags side-by-side on the shelf.
- The cooking durations depend on the thickness of the food.
- With higher temperatures and/or longer cooking durations, a lack of water may occur. Check the display from time to time.
- Keep the door closed during the cooking programme. Opening the door extends the programme and can change the cooking result.

- Temperatures and cooking durations from Sous-vide recipes cannot always be adopted exactly. Alter the settings to achieve the degree of cooking you want.

## Sous-vide (vacuum) cooking

---

### Tips

- To reduce preparation times, you can vacuum food 1–2 days before cooking. Store the vacuum sealed food in the refrigerator at a maximum temperature of 5 °C. To maintain quality and taste, the food must be cooked after a maximum of 2 days.
- Freeze liquids such as marinades before vacuum-sealing to prevent them from escaping from the bag.
- Fold the edges of the vacuum sealing bag outwards for filling in order to obtain clean, perfect seams.
- If you do not want to eat the food directly after cooking, put it in iced water to cool down completely. Then store it at a maximum temperature of 5 °C.

In this way, you can maintain quality and taste while extending the life of the food.

**Exception:** Consume poultry immediately after cooking.

- After cooking, cut the vacuum sealing bag on all sides for easier access to the food.
- Briefly fry meat and firm types of fish (such as salmon) before serving for a roasted aroma.

- Use the brine or marinade of vegetables, fish, or meat to make a sauce.
- Serve the food on pre-warmed plates.

# Sous-vide (vacuum) cooking

---

## Procedure

- Rinse the food with cold water and dry it.
- Place the food in a vacuum sealing bag and add spices or liquid if desired.
- Vacuum-seal the food in a chamber system vacuum sealer.
- For optimum cooking results place the rack on shelf level 2.
- Place the vacuum-sealed food on the rack (next to each other if there are several bags).
- Select Oven functions.
- Select Sous-vide.
- Change the recommended temperature if necessary.
- Confirm with OK.
- Set the cooking duration. Any time between 1 minute and 10 hours can be set.
- Confirm with OK.
- Select further settings if required (see "Operation: Steam cooking - Advanced operation").

## Possible reasons for unsatisfactory results

### The bag has opened:

- The seal was not clean or strong enough and has opened.
- The bag was damaged by a sharp bone.

### The food has an unpleasant or strange taste:

- Incorrect storage of the food; the food was kept out of the refrigerator for too long.
- The food was contaminated with bacteria before it was vacuum sealed.
- Too much of ingredients such as spices was added.
- The bag or seal was not in perfect order.
- The vacuum was insufficient.
- The food was not eaten or chilled immediately after cooking.

## Sous-vide (vacuum) cooking

Food	Added in advance		🌡️ [°C]	🕒 [min]
	Sugar	Salt		
<b>Fish</b>				
Atlantic cod fillet, 2.5 cm thick		x	54	35
Salmon fillet, 3 cm thick		x	52	30
Monk fish fillet		x	62	18
Pikeperch fillet, 2 cm thick		x	55	30
<b>Vegetables</b>				
Cauliflower florets, medium to large		x	85	40
Hokkaido pumpkin, sliced		x	85	15
Kohlrabi, sliced		x	85	30
White asparagus, whole	x	x	85	22–27
Sweet potato, sliced		x	85	18
<b>Fruit</b>				
Pineapple, sliced	x		85	75
Apples, sliced	x		80	20
Baby bananas, whole			62	10
Peaches, halved	x		62	25–30
Rhubarb pieces			75	13
Plums, halved	x		70	10–12
<b>Miscellaneous</b>				
Beans, white, soaked in a ratio of 1:2 (beans : liquid)		x	90	240
Prawns, peeled and deveined		x	56	19–21
Hen's egg, whole			65–66	60
Scallops, removed from shell			52	25
Shallots, whole	x	x	85	45–60

🌡️ Temperature / 🕒 Duration

## Sous-vide (vacuum) cooking

Food	Added in advance		🌡️ [°C]		🕒 [min]
	Sugar	Salt	Medium*	Well done*	
<b>Meat</b>					
Duck breast, whole		x	66	72	35
Saddle of lamb			58	62	50
Beef fillet steak, 4 cm thick			56	61	120
Beef rump steak, 2.5 cm thick			56	–	120
Pork fillet, whole		x	63	67	60

🌡️ Temperature / 🕒 Duration

\* Degree of doneness

The "Done" degree of doneness uses a higher core temperature than "Medium". Results are not the same as for well done in traditional roasting methods.

## Reheating

Only reheat brassicas, e.g. kohlrabi and cauliflower in combination with a sauce. Without sauce, an unpleasant cabbage-like taste and grey-brown colour may develop.

Food with a short cooking duration or which continues cooking during reheating, e.g. fish, is not suitable for reheating.

## Preparation

Place the cooked food into ice water for approx. 1 hour directly after cooking. The rapid cooling prevents the food from continuing to cook, which helps retain the optimum cooked condition. Then store the food in the refrigerator at a maximum temperature of 5 °C.

Please note that the quality of the food decreases the longer it is stored.

We recommend that you do not store the food in the refrigerator for longer than 5 days before reheating.

## Settings

Oven functions | Sous-vide

Temperature: see chart

Duration: see chart

# Sous-vide (vacuum) cooking

## Chart for reheating Sous-vide cooked food

Food	🌡️ [°C]		🕒 <sup>2</sup> [min]
	Medium <sup>1</sup>	Well done <sup>1</sup>	
<b>Meat</b>			
Saddle of lamb	58	62	30
Beef fillet steak, 4 cm thick	56	61	30
Beef rump steak, 2.5 cm thick	56	–	30
Pork fillet, whole	63	67	30
<b>Vegetables</b>			
Cauliflower florets, medium to large <sup>3</sup>	85		15
Kohlrabi, sliced <sup>3</sup>	85		10
<b>Fruit</b>			
Pineapple, sliced	85		10
<b>Miscellaneous</b>			
Beans, white, soaked in a ratio of 1:2 (beans : liquid)	90		10
Shallots, whole	85		10

🌡️ Temperature / 🕒 Duration

<sup>1</sup> Degree of doneness

The "Done" degree of doneness uses a higher core temperature than "Medium". Results are not the same as for well done in traditional roasting methods.

<sup>2</sup> Durations apply for food with an initial temperature of approx. 5 °C (refrigerator temperature).

<sup>3</sup> Reheat only in sauce.

## Reheat

To reheat food which was cooked using the Sous-vide method, use the Sous-vide function (see "Sous-vide (vacuum) cooking – Reheating").

The steam oven is very effective at reheating food gently, without drying it out or cooking it further. The food will reheat evenly and does not need to be stirred during the reheating process.

You can reheat individual dishes or plated meals which have been prepared previously (e.g. meat, vegetables and potatoes).

### Suitable containers

Small quantities can be reheated on a plate, larger quantities should be placed in a cooking container.

### Duration

10-15 minutes are usually sufficient for one plate of food. More than one plate will need a little longer.

If you are reheating several plated meals one after the other, the reheating time can be reduced by around 5 minutes for the second and subsequent plates as the oven will still be hot.

### Moisture

The more moist the food, the less moisture needs to be added.

## Tips

- Food does not need to be covered before it is reheated.
- Do not reheat large items, such as a joint of roast meat, whole. Divide it into portions and reheat these as plated meals.
- Compact items, such as stuffed peppers or roulades, should be cut in half.
- Please note that breaded items, such as schnitzel, will not retain their crispness when they are reheated.
- Reheat sauces separately, except for dishes such as stew and casseroles where the sauce is part of the dish.

## Settings

Special applications | Reheat  
or

Oven functions | Combi mode | Fan plus

Temperature: see chart

Moisture: see chart

Duration: see chart

## Special applications

Food	🌡️ [°C]	ΔΔ [%]	⌚ [min]
<b>Vegetables</b>			
Carrots Cauliflower Kohlrabi Beans	120	70	8–10
<b>Side dishes</b>			
Pasta Rice Potatoes, cut in half lengthways	120	70	8–10
Dumplings Mashed potato	140	70	18–20
<b>Meat and poultry</b>			
Sliced meat, 1 1/2 cm thick Roulades, sliced Goulash Lamb stew Chicken escalopes Turkey escalopes, sliced	140	70	11–13
<b>Fish</b>			
Fish fillet Fish roulade, halved	140	70	10–12
<b>Plated meals</b>			
Spaghetti, in tomato sauce Pork roast, potatoes and vegetables Stuffed peppers (cut in half), rice Chicken fricassee, rice Vegetable soup Creamed soup Clear broth Casserole	120	70	10–12

🌡️ Temperature / ΔΔ Moisture / ⌚ Duration

## Defrost

It is much quicker to defrost food in the steam oven than at room temperature.

### Temperature

60 °C is the best temperature for defrosting.

**Exception:** 50 °C for minced meat and game

### Before and after defrosting

Remove all packaging before defrosting.

**Exceptions:** Leave bread, biscuits and cakes in their packaging as otherwise they will absorb moisture and become soft.

Allow defrosted food to stand at room temperature after removing it from the oven. The standing time is necessary to allow the even distribution of heat.

### Cooking containers

 Danger of salmonella poisoning. Do not use the liquid from defrosted meat or poultry. Pour it away and wash the container, the sink and your hands.

Use a perforated container with a solid container underneath it when defrosting food which will drip, such as poultry. This way food will not be lying in defrosted liquid.

Food which does not drip can be defrosted in a solid container.

## Tips

- Fish does not need to be fully defrosted before cooking. Defrost so that the surface is sufficiently thawed to take herbs and seasoning. Depending on the thickness of the fish, 2 - 5 minutes should be enough.
- When defrosting food which has frozen together, e.g. berries, chops, fish fillets etc. separate it about half-way through the defrosting time.
- Do not refreeze food once it has thawed.
- Defrost frozen pre-cooked meals according to the manufacturer's instructions.

## Settings

Special applications | Defrost  
or

Oven functions | Steam cooking

Temperature: see chart

Defrosting duration: see chart

## Special applications

Food to be defrosted	Quantity	🌡️ [°C]	🕒 [min]	⌚ [min]
<b>Dairy products</b>				
Cheese slices	125 g	60	15	10
Quark	250 g	60	20–25	10–15
Cream	250 g	60	20–25	10–15
Soft cheese	100 g	60	15	10–15
<b>Fruit</b>				
Apple sauce	250 g	60	20–25	10–15
Apple pieces	250 g	60	20–25	10–15
Apricots	500 g	60	25–28	15–20
Strawberries	300 g	60	8–10	10–12
Raspberries / Blackcurrants	300 g	60	8	10–12
Cherries	150 g	60	15	10–15
Peaches	500 g	60	25–28	15–20
Plums	250 g	60	20–25	10–15
Gooseberries	250 g	60	20–22	10–15
<b>Vegetables</b>				
Frozen in a block	300 g	60	20–25	10–15
<b>Fish</b>				
Fish fillets	400 g	60	15	10–15
Trout	500 g	60	15–18	10–15
Lobster	300 g	60	25–30	10–15
Small shrimps	300 g	60	4–6	5
<b>Ready meals</b>				
Meat, vegetables, side dishes / Stew / Soup	480 g	60	20–25	10–15
<b>Meat</b>				
Roast meat, sliced	125–150 g each	60	8–10	15–20
Minced meat	250 g	50	15–20	10–15
Minced meat	500 g	50	20–30	10–15
Goulash	500 g	60	30–40	10–15

## Special applications

Food to be defrosted	Quantity	🌡️ [°C]	🕒 [min]	⌚ [min]
Goulash	1000 g	60	50–60	10–15
Liver	250 g	60	20–25	10–15
Saddle of hare	500 g	50	30–40	10–15
Saddle of roebuck	1000 g	50	40–50	10–15
Cutlets / chops / sausages	800 g	60	25–35	15–20
<b>Poultry</b>				
Chicken	1000 g	60	40	15–20
Chicken drumsticks	150 g	60	20–25	10–15
Chicken escalopes	500 g	60	25–30	10–15
Turkey drumsticks	500 g	60	40–45	10–15
<b>Baked goods</b>				
Puff pastries /Yeast buns	–	60	10–12	10–15
Creamed mixture cakes / biscuits	400 g	60	15	10–15
<b>Bread / rolls</b>				
Bread rolls	–	60	30	2
Rye bread, sliced	250 g	60	40	15
Whole grain bread, sliced	250 g	60	65	15
White bread, sliced	150 g	60	30	20

🌡️ Temperature / 🕒 Duration / ⌚ Standing time

# Special applications

---

## Bottling

Only use unblemished, fresh produce which is in good condition for bottling.

### Glass jars

Use clean glass jars and accessories and check them for any defects. Glass jars with twist off lids or glass lids with a rubber seal are suitable.

Make sure that all the jars are the same size so that bottling is carried out evenly.

After you have filled the jars with the bottled produce, clean the glass rims with a clean cloth and hot water and then seal the jars.

### Fruit

Sort fruit carefully, rinse it briefly but thoroughly and allow it to drain. Take great care when cleaning soft fruit as it is very delicate and squashes easily.

Remove any peel, stalks, cores or stones. Cut up large fruit. For example, cut apples into slices.

If you are bottling fruit with stones (e.g. plums, apricots) without removing the stones, pierce the fruit several times with a fork or wooden skewer as otherwise it will burst.

### Vegetables

Rinse, clean and cut up vegetables.

Vegetables should be blanched before bottling to help them retain their colour (see "Blanching").

## Fill volume

Fill the glass jars with produce up to a maximum of 3 cm below the rim. Do not pack it down as this will damage the cell walls of the produce. Tap the jar gently onto a cloth to help distribute the contents evenly. Fill the jars with liquid. The produce must be completely covered.

Use a sugar solution for fruit and a salt or vinegar solution for vegetables.

## Tips

- Make use of residual heat by leaving the jars in the oven for 30 minutes after it has switched off.
- Then cover the jars with a cloth and allow to cool for approx. 24 hours.

## Procedure

- Place a perforated container on the lowest shelf level.
- Place the jars in the cooking container (all the same size). Ensure that they do not touch one another.

## Settings



Special applications | Bottling

or

Oven functions | Steam cooking

Temperature: see chart

Bottling duration: see chart

Produce	 [°C]	 * [min]
<b>Berries</b>		
Red / blackcurrants	80	50
Gooseberries	80	55
Cranberries	80	55
<b>Fruit with stones</b>		
Cherries	85	55
Mirabelle plums	85	55
Plums	85	55
Peaches	85	55
Greengages	85	55
<b>Fruit with pips</b>		
Apples	90	50
Apple sauce	90	65
Quinces	90	65
<b>Vegetables</b>		
Beans	100	120
Broad beans	100	120
Gherkins	90	55

## Special applications

---

Produce	🌡️ [°C]	🕒* [min]
Beetroot	100	60

🌡️ Temperature / 🕒 Duration

\* The durations quoted are for 1.0 litre jars. If using 0.5 litre jars, reduce the duration by about 15 minutes. If using 0.25 litre jars, reduce the duration by about 20 minutes.

## Bottling cakes

Creamed, sponge and yeast dough mixtures are all suitable for bottling. Cakes will keep for approx. 6 months.

Cakes **made with fresh fruit** are **not suitable for long term storage**, and must be consumed within 2 days of being made.

### Glass jars







Only use clean jars and accessories which are in perfect condition. Jars should be narrower at the bottom than the top. 0.25 litre jars are the most suitable for bottling cakes.

Jars must have a glass lid with metal spring clamp to seal them.

Make sure that all the jars are the same size so that bottling is carried out evenly.

### Procedure

- Grease the inside of the jars with butter up to 1 cm below the rim.
- Sprinkle inside the jars with fine breadcrumbs.
- Fill the jars  $\frac{1}{2}$  to  $\frac{2}{3}$  full with cake mixture (depending on recipe). Make sure the rim stays clean.
- Place the rack on the second shelf level.
- Place the jars on the rack (all the same size) **without lids on**. Ensure that they do not touch one another.
- Close the jars **immediately** after bottling by clamping the glass lid down securely. Do not let the cakes cool down. If the mixture has risen above the rim, it can be pushed back down into the jar with the glass lid.

Type of mixture	Function	Stage	🌡️ [°C]	ΔΔ [%]	🕒 [min]
Creamed mixture		–	160	–	25–45
Sponge		–	160	–	50–55
Yeast dough	 	1	30	100	10
	 	2	160	30	30–35

🌡️ Temperature / ΔΔ Moisture / 🕒 Duration

 Conventional heat /   Combi mode Conventional heat

# Special applications

---

## Extracting juice with steam

This appliance is ideal for extracting juice from soft and medium firm fruit.

It is best to use overripe fruit, as the riper the fruit the greater the quantity of juice produced. Very ripe fruit will also produce a more intense flavour.

### Preparation

Sort and clean the fruit. Cut out any blemishes.

Remove the stalks from grapes and morello cherries as these are bitter. The stalks do not need to be removed from raspberries etc.

Cut larger fruit into chunks approx. 2 cm in size. The harder the fruit the smaller the pieces should be.

### Tips

- Try experimenting with mild and tart fruit.
- Adding sugar will increase the quantity of juice produced and improve the flavour. Sprinkle the fruit with sugar and leave to absorb for a few hours before juicing. For 1 kg of sweet fruit add 50–100 g of sugar, and for 1 kg of tart fruit add 100–150 g of sugar.
- If you wish to bottle the juice rather than consume it straight away, pour it whilst hot into hot, sterilised bottles, and then seal immediately with sterilised tops.

### Procedure

- Put the prepared fruit (cleaned, washed, chopped etc.) into a perforated cooking container.
- Place a solid container or the universal tray underneath to catch the juice.

### Settings

Oven functions | Steam cooking

Temperature: 100 °C

Duration: 40–70 minutes

## Menu cooking (cooking whole meals)

You can cook up to three different types of food, e.g. fish with a side dish and vegetables.

The food can be selected in any order you like. The appliance will automatically sort them out in order of cooking duration required. The one with the longest duration goes in the oven first.

The Ready at and Start at functions are not available with Menu cooking.

After you have confirmed Start menu cooking, the display will tell you which food to put in the oven. At the end of the heating-up phase, the display will show when the next food type is to be placed in the oven. This process will be repeated for the third food type.

You can still cook food types not listed in the display together. See "Menu cooking - manually" for details on how to do this.

### Procedure

- Switch the steam oven on.
- Fill the water container and push it back in so that it connects.
- Then place the condensate tray / universal tray (depending on model) in the appliance.
- Select Special applications | Menu cooking.
- Select the food you want.

Depending on the type of food selected, you will be asked about the size and how well done you want it cooked.

- Select or enter the values required and then confirm your selection with OK.
- Select Add next ingredient.
- Select the next food you want and proceed in the same way as with the first one.
- Repeat for the third type of food.

# Special applications

---

## Drying food

Only use the special application **Drying** or the **Combi mode** | **Fan plus** function to dry food so that moisture can be dissipated.

### Procedure

- Cut the produce into similar sized pieces.
- Spread out across the rack covered in baking parchment.

**Tip:** Bananas and pineapple are not suitable for drying.

### Settings

Special applications | **Drying**

Temperature: see chart

Duration: see chart

or

Oven functions | **Combi mode** | **Fan plus**

Temperature: see chart

Duration: see chart

Moisture: 0 %

Food	🌡️ [°C]	🕒 [h]
Apple, rings	70	6–8
Apricots, halved, stones removed	60–70	10–12
Pears, sliced	70	7–9
Herbs	60	1.5–2.5
Mushrooms	70	3–5
Tomatoes, sliced	70	7–9
Citrus fruit, sliced	70	8–9
Damsons, stones removed	60–70	10–12

🌡️ Temperature / 🕒 Duration (hours)

### Make yoghurt

To make yoghurt, you will need either fresh live yoghurt or yoghurt culture, obtainable from health food shops.

Use natural yoghurt with live culture and without additives. Heat-treated yoghurt is not suitable.

The yoghurt must be fresh (short storage time).

You can use either unchilled long-life or fresh milk.

Long-life milk can be used without any further treatment. Fresh milk must first be heated to 90 °C and then cooled down to 35 °C. Do not boil it. Fresh milk will give a better set than long-life milk.

The yoghurt and milk should have the same percentage fat.

Do not move or shake the jars whilst the yoghurt is thickening.

Immediately after preparation leave the yoghurt to cool in the fridge.

How well home prepared yoghurt sets will depend on the consistency, fat content and the cultures used in the starter yogurt. Not all yoghurts are suitable for use as starter yoghurt.

### Possible reasons for unsatisfactory results

#### Yoghurt has not set:

Incorrect storage of starter yoghurt, too much time out of the refrigerator, e.g. in transportation, damaged packaging, milk not sufficiently heated.

#### Liquid has separated:

The jars were moved, yoghurt was not cooled down quickly enough.

#### Yoghurt is gritty:

Milk was overheated or in poor condition, milk and starter yoghurt not evenly stirred.

**Tip:** When using yoghurt enzyme, yoghurt can be made from a milk / cream mixture. Mix  $\frac{3}{4}$  litre milk with  $\frac{1}{4}$  litre cream.

# Special applications

---

## Procedure

- Mix 100 g yoghurt with 1 litre of milk or make up the mixture with yoghurt enzyme, following the instructions on the packaging.
- Pour the mixture into jars and seal the jars.
- Place the sealed jars in a perforated container making sure they do not touch one another.
- Immediately after the yoghurt has been made, place the jars in the refrigerator, taking care not to shake them unnecessarily.

## Settings

Automatic programmes | Special | Make yoghurt

or

Oven functions | Steam cooking  
Temperature: 40 °C  
Duration: 5:00 hours

## Prove dough

### Procedure

- Prepare the dough according to the recipe.
- Place the dough in an uncovered bowl in a perforated container or on the rack.

### Settings

Special applications | Prove dough

Duration: as per recipe instructions

or

Oven functions | Combi mode | Fan plus

Moisture: 100 %

Temperature: 30 °C

Duration: as per recipe instructions

## Dissolve gelatine

### Procedure

- **Gelatine leaves:** Completely cover the gelatine leaves with cold water and leave to soak for 5 minutes. Remove the gelatine leaves from the bowl and squeeze them out. Empty the bowl. Place the squeezed gelatine leaves back in the bowl.
- **Gelatine powder:** Place in a bowl and add water according to the instructions on the packaging.
- Cover the bowl and place in a perforated container.

### Settings

Automatic programmes | Special | Dissolve gelatine

or

Oven functions | Steam cooking

Temperature: 90 °C

Duration: 1 minute

## Melt chocolate

You can use the steam oven for melting any type of chocolate.

### Procedure

- Break the chocolate into small pieces. Leave chocolate cake covering in its packaging, and place in a perforated cooking container.
- Place large quantities in a solid cooking container and small quantities in a cup or a bowl.
- Cover the container or the dish with a lid or with foil that is resistant to temperatures up to 100 °C and to hot steam.
- Stir large quantities once halfway through cooking.

### Settings

Automatic programmes | Special | Melt chocolate

or

Oven functions | Steam cooking

Temperature: 65 °C

Duration: 20 minutes

# Special applications

## Skinning vegetables and fruit

### Procedure

- Cut a cross in the top of tomatoes, nectarines etc. This will allow the skin to be removed more easily.
- Place the fruit / vegetables in a perforated cooking container if using steam cooking and in the universal tray if using the grill.
- To blanch almonds, it is important to plunge them into cold water as soon as they are taken out of the oven otherwise the skin cannot be removed.

### Settings

Oven functions | Full grill

Grill level: 3

Duration: see chart

Food	🕒 [min]
Peppers	10
Tomatoes	7

🕒 Duration

Oven functions | Steam cooking

Temperature: 100 °C

Duration: see chart

Food	🕒 [min]
Apricots	1
Almonds	1
Nectarines	1
Peppers	4
Peaches	1
Tomatoes	1

🕒 Duration

### Apple storage

You can treat homegrown apples in the steam oven to increase the length of time for which you can store them.

Once treated, the apples will keep for 5 to 6 months when stored in a dry, cool and well-ventilated place. This method is only suitable for apples and not for other types of fruit.

### Settings

Automatic programmes | Fruit | Apples | Whole | Preserving

or

Oven functions | Steam cooking

Temperature: 50 °C

Duration: 5 minutes

### Blanching

Blanch vegetables before freezing them. Blanching helps maintain the quality of the produce when it is frozen.

Blanching vegetables also helps them retain their original colour.

### Procedure

- Put the prepared vegetables into a perforated cooking container.
- Once blanched, plunge the vegetables into ice cold water to cool them down quickly. Drain them well.

### Settings

Special applications | Blanching

or

Oven functions | Steam cooking

Temperature: 100 °C

Duration: 1 minute

## Special applications

---

### Sweat onions

Sweating means cooking the onions in their own juices, with the addition of a little fat if necessary.

#### Procedure

- Cut the onions up into small pieces and place them in a solid cooking container with a little butter.
- Cover the container or the dish with a lid or with foil that is resistant to temperatures up to 100 °C and to hot steam.

#### Settings

Automatic programmes | Special | Sweat onions

or

Oven functions | Steam cooking  
Temperature: 100 °C  
Duration: 4 minutes

### Cook bacon

The bacon does not brown.

#### Procedure

- Place the bacon (diced or rashers) in a solid cooking container.
- Cover the container with a lid or with foil that is temperature resistant up to 100 °C and to steam.

#### Settings

Automatic programmes | Special | Cook bacon

or

Oven functions | Steam cooking  
Temperature: 100 °C  
Duration: 4 minutes

## Disinfect items

The steam oven can be used to disinfect baby bottles and other containers so that at the end of the programme they are as germ free as they would have been had they been boiled. Check beforehand that all parts, teats etc. are declared by the manufacturer to be heat resistant to 100 °C and also that they can withstand hot steam.

Dismantle, clean and thoroughly rinse baby bottles. All parts of the bottles must be completely dry before they are reassembled to keep them germ free.

### Procedure

- Place the individual items on the rack or in a perforated container (on their sides or with the opening facing downwards) ensuring that they do not touch one another to allow hot steam to reach them from all sides.
- Place the rack or container on the lowest shelf level.

### Settings

Special applications | Disinfect items

Duration: 1 minute to 10 hours

or

Oven functions | Steam cooking

Temperature: 100 °C

Duration: 15 minutes

## Heat damp flannels

### Procedure

- Moisten the flannels and then roll them up.
- Place them beside one another in a perforated cooking container.

### Settings

Automatic programmes | Special | Heat damp flannels

or

Oven functions | Steam cooking

Temperature: 70 °C

Duration: 2 minutes

## Special applications

---

### Decrystallise honey

#### Procedure

- Loosen the lid and place the jar of honey in a perforated container.
- Stir the honey once during the cooking duration.

#### Settings

Automatic programmes | Special |  
Decrystallise honey

or

Oven functions | Steam cooking  
Temperature: 60 °C  
Duration: 90 minutes (irrespective of the size of jar or the amount of honey in the jar)

### Pizza

#### Settings

Special applications | Pizza

or

Oven functions | Fan plus  
Temperature: 180–225 °C  
Duration: 1–20 minutes  
Tip: Use the rack lined with baking parchment

### Making eierstich

#### Procedure

- Mix 6 eggs with 375 ml milk (do not beat until foamy).
- Season the egg and milk mixture and pour into a greased solid cooking container with a little butter.

#### Settings

Oven functions | Steam cooking  
Temperature: 100 °C  
Duration: 4 minutes

## Making preserves

Only use unblemished, fresh produce which is in good condition.

### Glass jars

Only use sterilised jars with twist-off lids up to a maximum capacity of 250 ml.

After pouring in the fruit, clean the rim of the jar with a clean cloth and hot water.

### Preparation

Sort fruit carefully, rinse it briefly but thoroughly and allow it to drain. Take great care when cleaning soft fruit as it is very delicate and squashes easily. Remove any stalks, cores or stones.

Purée the fruit as otherwise the preserve will not set. Add jam sugar to the fruit (according to packet instructions) and stir well.

For sweet fruit and berries you should also add some citric acid.

### Procedure

- Fill jars maximum 2/3 full.
- Place the jars without their lids on in a perforated container or on the rack.
- At the end of the programme take the jars out of the steam oven using oven gloves. Leave them to stand for 1 - 2 minutes before sealing them with twist off lids and then leave them to cool.

### Settings

Oven functions | Combi mode | Fan plus  
Temperature: 150 °C  
Moisture: 0 %  
Duration: 35 minutes

# Special applications

## Sabbath programme

This programme is for religious observance.

The programme operates with Conventional heat and cannot be changed.

The programme will only start after the door is opened and closed:

- The steam oven will heat up to the temperature you have set and will maintain this temperature for a maximum of 72 hours.
- Sabbath programme appears constantly in the display.
- The time of day display is switched off.
- The interior lighting does not come on, even when the door is opened.

If the Lighting | On setting has been selected, the lighting remains switched on when the Sabbath programme has been selected and will stay on for the duration of the programme.

The Sabbath programme cannot be selected if the minute minder is being used.

### Procedure

- Select Special applications.
- Select Sabbath programme.
- Set the required temperature.
- Confirm with OK.

Sabbath programme and the set temperature will appear in the display.

The oven is ready for use.

- Open the door when you want to start the programme.
- Place the food in the oven.
- Close the door.

The programme will start after approximately 5 minutes.

A Sabbath programme that has been started cannot be changed, nor can it be saved under User programmes.

If you want to end the programme early:

- Switch the steam oven off.

## How the food probe works

The metal tip of the food probe is inserted into the food. There is a temperature sensor in the metal tip which measures the core temperature of the food during cooking.

The core temperature set will depend on how well cooked you want your meat to be and on the type of meat. The temperature can be set between 30 and 99 °C.

The cooking duration will depend on a number of different factors. The higher the temperature in the oven compartment and the moisture, where applicable and the thinner the meat, the quicker the set core temperature will be reached.

The cooking programme will finish automatically when the core temperature in the meat reaches the value set for the food probe. Exception: In Combi mode mode or User programmes where another cooking stage e.g. browning has been set.

The food probe will be damaged if used incorrectly.

If you are not using the food probe remove it from the oven when cooking.

It is only protected from overheating when it is plugged in.

## When to use it

The food probe can be used in the following operating modes:

- Combi mode | Fan plus
- Combi mode | Conventional heat
- Fan plus
- Fan grill
- Conventional heat
- Intensive bake
- Cake plus
- Steam cooking
- Reheat

# Food probe

## Important notes about using the food probe

The food probe handle and the cable must not touch the top heating element/grill element during cooking.

**Danger of breaking.**

Do not use the food probe to lift or carry the food.

The metal tip of the food probe must be fully inserted into the centre of the food.

Do not let the metal tip touch any bones or insert it into a particularly fatty area of the meat. Contact with fat or bone can lead to the oven being switched off too early.

If the meat is very heavily marbled with fat, select the highest core temperature given in the chart.

When using roasting bags, insert the probe through the bag into the centre of the meat.

You can also place the meat, with the food probe inserted, inside the bag. Follow the roasting bag manufacturer's instructions.

If wrapping meat in aluminium foil, the food probe must be inserted through the foil to the centre of the meat.

## Procedure

- Prepare the meat in the usual way.
- Insert the metal tip of the food probe fully into the food.
- Place the food in the oven.

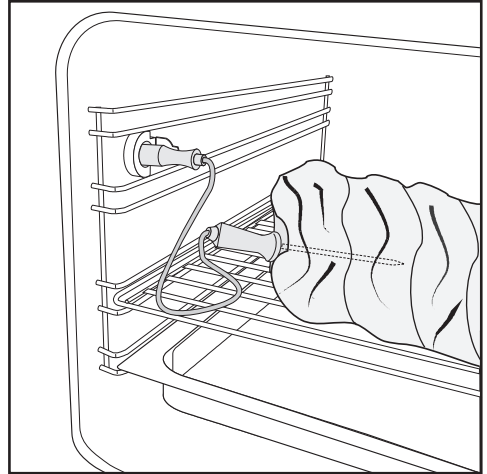

- Open the connection socket for the food probe and insert the plug of the food probe into the socket until you feel it engage.
- Select the function you want.
- Alter the recommended and / or core temperature if necessary.

After cooking:

**⚠ Danger of burning.**  
The food probe can get hot.

- Before taking the food out of the oven, carefully remove the food probe plug from the connection socket.

## Tips

- If you are cooking several pieces of meat together, insert the food probe in the largest piece of meat.
- If the food is not cooked sufficiently when the core temperature is reached, insert the food probe into another place or increase the core temperature and repeat the programme.

Meat	 [°C]
Roast veal	75–80
Gammon joint	75
Leg of lamb	80–85
Saddle of lamb	70–75
Saddle of roebuck / hare	65–75
Roast beef	80–90
Fillet of beef / Sirloin joint	
rare	45
medium	55
well done	75
Pork / Blade roast	80–90
Pork tenderloin / Chump end	75
Game / Rump cut	80–90

 Core temperature

# Roasting

---

## Roasting tips

- Insert the grease filter in the back panel when roasting.

Frozen meat must be defrosted before it is cooked.

- Always defrost meat before roasting.
- Remove skin and sinew before roasting.
- Season the meat to taste and dot with butter, or in the case of game, bard with rashers of streaky bacon.

**Tip:** Game can be marinated overnight e.g. in buttermilk, to tenderise it.

- If you are cooking several pieces of meat together, select pieces that are similar in size.
- Roast meat on the rack above the universal tray. The meat juices will collect in the tray and can then be used to make a gravy or sauce.
- Allow a standing time of approx. 10 minutes before carving meat to allow the meat juices to be evenly distributed.

We recommend the Combi mode | Fan plus and Combi mode | Conventional heat functions for roasting.

If you wish to use other functions you can enter your cooking stages as a User programme (see "User programmes").

## Combination mode

The lower the temperature in the oven, the longer the cooking duration and the more tender the result.

## Lean meat

The addition of steam prevents the surface of lean meat from drying out. Excellent results can be achieved when using 5 cooking stages for the programme.

- Cooking stage 1: pre-heat the oven with the rack above the universal tray.
- Cooking stage 2: brown the meat.
- Cooking stage 3: adjust the temperature to a temperature suitable for continued roasting.
- Cooking stage 4: cook until tender.
- Cooking stage 5: continue cooking to the required level of "doneness".

## **Fatty meat** with crackling

- Cooking stage 1: use a high temperature to render the fat and brown the crackling.
- Cooking stage 2: reduce the temperature and increase the moisture
- Cooking stage 3: increase the temperature for crispy crackling.

## **Braised dishes**

- Cooking stage 1: pre-heat the oven and the universal tray.
- Cooking stage 2: brown the meat.
- Cooking stage 3: braise the meat at a temperature of 100 °C with 84 % moisture.





















































## **Poultry**

- Cooking stage 1: use a high temperature and a high moisture level to render the fat.
- Cooking stage 2: lower the temperature.
- Cooking stage 3: increase the temperature and reduce the humidity to dry out and crisp the skin.





























Please refer to the roasting chart which follows for details on the settings.

# Roasting















































## Roasting chart

Type of meat	Stage	Function	 [°C]	 [%]	 [min]	 [°C]
<b>Poultry</b>						
Duck up to 2 kg, stuffed	1	 	190	40	20	–
	2	 	100	80	140	–
	3		190	–	23	–
Duck up to 2 kg, unstuffed	1	 	190	40	20	–
	2	 	100	80	100	–
	3		190	–	23	–
Duck breast, rare	1	 	Level 3	0	15	–
	2	 	30	0	20	–
	3	 	Level 3	0	7–13	–
Duck breast, well done	1	 	Level 3	0	15	–
	2	 	30	0	20	–
	3	 	Level 3	0	7–13	–
	4	 	30	0	5	–
Goose, approx. 4.5 kg	1	 	190	40	30	–
	2	 	100	80	270	–
	3		190	–	23	–
Chicken, whole	1	 	225	0	20	–
	2	 	150	55	60	–
	3	 	Level 3	0	2–12	–
Chicken drumsticks	1	 	200	95	30–25	–
	2	 	225	0	13–18	–
	3	 	Level 3	0	0–7	–
Turkey roulade, stuffed/unstuffed	1	 	190	40	20	–
	2	 	140	75	100	–
	3		200	–	4–8	–
Turkey breast	1	 	170	65	85	–
	2		Level 3	–	0–9	–





















































# Roasting

Type of meat	Stage	Function	 [°C]	 [%]	 [min]	 [°C]
<b>Veal</b>						
Fillet/saddle (roast)						
rare	–		175	–	–	45
medium	–		165	–	–	55
well done	–		160	–	–	75
Fillet/saddle (roast with moisture)						
rare*	1		Level 3	0	10	–
	2		Level 3	0	8	–
	3		60	0	30	–
	4		60	49	30	–
medium*	1		Level 3	0	10	–
	2		Level 3	0	10	–
	3		100	0	20	–
	4		65	49	60	–
	5		70	51	60	–
Fillet (roast with moisture)						
Well done*	1		Level 3	0	10	–
	2		Level 3	0	10	–
	3		100	0	20	–
	4		65	49	60	–
	5		90	68	50	–
	6		200	–	5	–
Saddle / crown roast (roast with moisture)						
Well done*	1		Level 3	0	10	–
	2		Level 3	0	10	–
	3		100	0	20	–
	4		65	49	60	–
	5		90	68	80	–
	6		200	–	5	–

# Roasting

Type of meat	Stage	Function	 [°C]	 [%]	 [min]	 [°C]
Shank	1	 	100	84	155	–
	2	 	190	–	17	–
Pot roast*	1	 	Level 3	0	10	–
	2	 	Level 3	0	10	–
	3	 	100	84	165	–
<b>Lamb</b>						
Leg of lamb	1		Level 3	–	18	–
	2	 	100	57	190	–
Saddle / crown roast Medium*	1		Level 3	–	10	–
	2		Level 3	–	8	–
	3	 	30	0	30	–
	4	 	75	47	40	–
Well done*	1		Level 3	–	10	–
	2		Level 3	–	10	–
	3	 	30	0	30	–
	4	 	100	57	100	–
<b>Pork</b>						
Fillet	–		200	–	–	75
Gammon joint	1	 	200	0	30	–
	2	 	130	100	–	75
Pork with crackling	1	 	225	54	40	–
	2	 	100	84	120	–
	3		165–185	–	20–25	–
Pork loin	1	 	180	50	30	–
	2	 	130	30	–	75
<b>Beef</b>						
Fillet (roast)						
rare	–		175	–	–	45
medium	–		170	–	–	55
well done	–		165	–	–	75

# Roasting

Type of meat	Stage	Function	 [°C]	 [%]	 [min]	 [°C]
Fillet (roast with moisture)  rare*   medium*	1	 	Level 3	0	10	–
	2	 	Level 3	0	10	–
	3	 	60	0	30	–
	4	 	60	49	30	–
	1	 	Level 3	0	10	–
	2	 	Level 3	0	10	–
	3	 	100	0	20	–
	4	 	65	49	60	–
	5	 	70	51	60	–
	6		200	–	8	–
Fillet (roast with moisture)  Well done*	1	 	Level 3	0	10	–
	2	 	Level 3	0	10	–
	3	 	100	0	20	–
	4	 	65	49	60	–
Sirloin joint (roast)  rare medium well done	–		175	–	–	45
	–		170	–	–	55
	–		165	–	–	75
Sirloin joint (roast with moisture)  rare*   medium*	1	 	Level 3	0	10	–
	2	 	Level 3	0	10	–
	3	 	60	0	30	–
	4	 	60	49	30	–
	1	 	Level 3	0	10	–
	2	 	Level 3	0	10	–
	3	 	100	0	20	–
	4	 	65	49	60	–
	5	 	70	51	60	–

# Roasting

Type of meat	Stage	Function	🌡️ [°C]	⏪ [%]	🕒 [min]	🔥 [°C]
Well done*	1		Level 3	0	10	–
	2		Level 3	0	10	–
	3		100	0	20	–
	4		65	49	60	–
	5		90	68	135	–
	6		200	–	8	–
Roulades**	1		Level 3	0	10	–
	2		Level 3	0	10	–
	3		100	84	120	–
Pot roast**	1		Level 3	0	10	–
	2		Level 3	0	10	–
	3		100	84	205	–
<b>Game</b>						
Saddle of roebuck or venison medium*	1		Level 3	–	10	–
	2		Level 3	–	7	–
	3		30	0	30	–
	4		75	52	40	–
Well done*	1		Level 3	–	10	–
	2		Level 3	–	13	–
	3		30	0	30	–
	4		100	47	107	–
Venison rump	1		Level 3	–	20	–
	2		100	57	160	–
Saddle of roebuck medium*	1		Level 3	–	10	–
	2		Level 3	–	10	–
	3		30	0	15	–
	4		75	47	55	–
Well done*	1		Level 3	–	10	–
	2		Level 3	–	10	–
	3		100	47	84	–

# Roasting

Type of meat	Stage	Function	🌡️ [°C]	💧 [%]	🕒 [min]	🍖 [°C]
Roebuck rump	1		Level 3	–	20	–
	2		100	57	130	–
Wild boar, rump cut	1		Level 3	–	20	–
	2		100	57	145	–
<b>Miscellaneous</b>						
Ostrich rare*	1		Level 3	–	10	–
	2		Level 3	–	8	–
	3		30	0	15	–
	4		65	49	157	–
medium*	1		Level 3	–	10	–
	2		Level 3	–	13	–
	3		30	0	15	–
	4		80	66	157	–
Well done*	1		Level 3	–	10	–
	2		Level 3	–	13	–
	3		30	0	30	–
	4		100	57	142	–

🌡️ Temperature/Grill level / 💧 Moisture / 🕒 Duration / 🍖 Core temperature

Combi mode Fan plus / Combi mode Full grill / Combi mode Conventional heat / Full grill / Fan grill

\* In stage 1 place the universal tray on shelf level 2 and the rack on shelf level 3 without food on it and pre-heat the oven. Place the meat on the pre-heated rack at the beginning of stage 2.

\*\* In stage 1 place the universal tray on shelf level 3 without food on it and pre-heat the oven. Place the meat on the pre-heated universal tray at the beginning of stage 2.

# Baking

---

Eating food which has been cooked correctly is important for good health.  
Only bake cakes, pizza, chips etc. until they are golden. Do not overcook them.

## Fan plus

For baking on several levels

- When using Fan plus, reduce the temperatures given for Conventional heat by about 20 °C.

## Conventional heat

For baking traditional recipes, e.g. rich fruit cake and making soufflés.

- Only bake on one level at a time.
- Bake tray bakes on shelf level 3 and cakes in tins on shelf level 2.
- If using an older recipe or cookbook, set the oven temperature for Conventional heat 10 °C lower than that recommended. This will not change cooking durations.

## Top heat

Select at the end of the cooking duration to brown the topping on a dish. For gratins and bakes.

## Bottom heat

Use this setting towards the end of baking, to brown the base of a cake, quiche or pizza.

## Cake plus

For creamed mixtures, choux pastry (e.g. eclairs) and frozen pretzels.

## Intensive bake

For baking cakes with a moist topping, e.g. cheese cake, fresh fruit cakes, quiche and flans. Also suitable for items such as pizza without the need to pre-bake the base.

- Use the bottom shelf level.

## Combination mode

The gleaming finish on bread, rolls and puff pastry is achieved by adding steam (maximum moisture, low temperature) in cooking stage 1. Browning is achieved using a high moisture level and a high temperature. The drying out phase takes place with low moisture and a high temperature.

## Baking tips

### Grease filter

- Remove the grease filter from the back panel as otherwise results can be uneven. (Exception: Flans with a deep, fresh fruit filling, e.g. plums or damsons, pizza with lots of topping).

### Bakeware

- Dark-coloured tins are best for baking. These conduct the heat more swiftly to the mixture. Shiny metal tins reflect heat.

Cakes in shiny metal tins take longer to cook.

- Bake cakes in rectangular tins with the longer side across the width of the oven for optimum heat distribution and even results.
- For Automatic programmes please refer to the cookbook for information on suitable baking containers.

### Universal tray

Because of its PerfectClean non-stick surface the universal tray does not need to be greased or lined with baking parchment for baking.

### Shelf level

- Bake on a maximum of two levels at the same time. When baking on two levels at the same time, follow the instructions given in "Automatic programmes".

### Baking parchment

Baking parchment should be used with:

- Anything with a high salt content (e.g. pretzels, bread sticks), because sodium can damage the PerfectClean surface,
- Meringues or sponges with a high egg-white content, because they are more likely to stick.
- Puff pastry

# Baking

---

## Frozen food

- When baking deep frozen products such as chips, croquettes, cakes, pizza and baguettes, use the lowest temperature quoted on the manufacturer's packaging.
- Cook frozen goods such as cakes, pizza or baguettes on a layer of baking parchment placed on the rack.



























Baking large frozen items on the universal tray can cause the metal to distort to such an extent that the tray cannot be taken out of the oven.

- Small items of frozen food such as oven chips or potato croquettes can be cooked on the universal tray. Place them on baking parchment and turn several times during cooking.

## Notes on the baking chart

























- As a general rule, select the lower temperature given in the chart.
- Do not set a temperature higher than that recommended. Increasing the temperature may reduce the baking duration, but will lead to uneven browning, and unsatisfactory cooking results.
- Check if the food is cooked at the end of the shortest duration quoted. To check if a cake is ready, insert a wooden skewer into the centre. It is ready if the skewer comes out clean, without dough or crumbs sticking to it.

## Baking chart



Food	Stage	Function	🔥 [°C]	ΔΔ [%]	🕒 [min]
<b>Sponge mix</b>					
Tray	–		150–180	–	25
Springform tin	–		160–170	–	25–35
<b>Puff pastry</b>					
Filled	1		100	100	7
	2		190–210	90	10
	3		190–210	75	5
	4		190–210	0	6
Small pastries*	–		180	–	15
<b>Choux pastry</b>					
Choux buns / Éclairs	–		150–185	0	50
<b>Yeast dough</b>					
Bagels	1		100	100	10
	2		200	0	24
Baguettes, spelt bread	1		40	100	8
	2		50	100	4
	3		210	50	6
	4		180–210	0	30
Butter cake	1		160	90	15
	2		120–165	0	10
Croissants	1		90	100	2
	2		160	90	10
	3		160–190	0	27
Triple grain bread	1		30	100	15
	2		150	50	10
	3		150	0	100
Flat bread	1		40	100	10
	2		50	100	2
	3		210	0	6
	4		155–190	0	25

# Baking

Food	Stage	Function	🌡️ [°C]	ΔΔ [%]	🕒 [min]
Plaited loaf	1		40	100	8
	2		50	100	2
	3		200	50	10
	4		160–200	0	12
White bread in tin	1		40	100	8
	2		50	100	4
	3		210	50	6
	4		220	0	25–50
Herb rolls	1		155	90	9
	2		200	0	15–25
Multigrain rolls	1		155	90	9
	2		210	0	20–30
Pizza / Plum cake	–		175–205	–	35
Plaited Swiss loaf	1		90	100	6
	2		170–210	50	45
Stollen	1		150	100	30
	2		130–160	0	30
Streusel cake	1		30	100	30
	2		160	90	25
	3		130–180	0	10
Sweet rolls	1		40	100	8
	2		50	100	2
	3		200	50	10
	4		200	0	8–13
Wholegrain bread	1		40	100	8
	2		50	100	4
	3		210	50	6
	4		190–215	0	30
White bread	1		40	100	8
	2		50	100	4
	3		210	50	6
	4		170–210	0	30
White rolls	1		155	90	9
	2		200	0	20–30

Food	Stage	Function	🔥 [°C]	∆∆ [%]	🕒 [min]
Mixed wheatgrain bread	1		40	100	8
	2		50	100	4
	3		210	50	6
	4		180–220	0	30
Onion tart	–		190	–	25–35
<b>Shortcrust pastry</b>					
Small cakes	1		185	50	6
	2		185	0	10–15
Tin with dry topping	–		200	85	35
Tin with moist topping*	1		210	0	15
	2		190	0	20–30
Tray bake with topping	–		170–190	–	35–45
<b>Quark dough</b>					
Sweet rolls	1		50	100	5
	2		165	50	5
	3		165	0	14–26
Pizza	–		155–185	–	30
Tray bake	–		160–180	–	45–55
<b>Creamed mixture</b>					
Cake tin	–		170–190	–	55
Tray bake with fruit topping	–		170–190	–	40
Small cakes	–		150–190	95	25
Baumkuchen	–		Level 3	–	2–3**
<b>Sourdough</b>					
Mixed rye bread	1		210	50	5
	2		190–210	0	50
Rye bread	1		210	60	6
	2		210	0	6
	3		155–170	0	60

# Baking

Food	Stage	Function	🌡️ [°C]	💧 [%]	🕒 [min]
<b>Strudel</b>					
Apple strudel	1		30	90	7
	2		190	0	35–60

🌡️ Temperature/Grill level / 💧 Moisture / 🕒 Duration

  Combi mode Fan plus /  Combi mode Conventional heat /

 Conventional heat /  Fan plus /  Intensive bake /  Cake plus /  Full grill

\* Pre-heat the oven with nothing in it.

\*\* Per layer



**Danger of burning.**

The appliance door must remain shut during grilling, as otherwise the controls will get hot.

The food probe cannot be used with Full grill, Economy grill and Combi mode | Full grill.

## Full grill

For grilling thin cuts in large quantities and for browning large baked dishes.

## Economy grill

For grilling thin cuts in small quantities and for browning small baked dishes

## Fan grill

For grilling thicker items, e.g. rolled meat, poultry pieces.

## Grilling tips

- Place the food on the rack on top of universal tray.
- When grilling fish, place the fish on a piece of baking paper cut to size.
- Place the food in the steam oven without pre-heating. Pre-heating the steam oven is not necessary when grilling.
- Grill thick items, e.g. half a chicken, in the middle and thin items, e.g. steak, on the top shelf level.
- Turn the food after  $\frac{2}{3}$  of the cooking time has elapsed. Fish does not need to be turned.









# Grilling

---

## Tips

- Marinate or add a little oil if necessary to lean meat. Do not use other types of fat as they can burn and cause smoke.
- Pierce sausages before grilling.
- It is best to grill food of a similar thickness at the same time so that the grilling time for each item does not vary too greatly.
- To grill thicker pieces of food more gradually after an initial high temperature, continue grilling at a lower temperature setting or use a lower shelf runner to allow the food to cook through to the centre.
- One way of finding out how far through a piece of meat has been cooked is to press down on it with a spoon.
  - If there is very little resistance to the pressure of the spoon, it will still be red on the inside ("rare").
  - If there is some resistance the inside will be pink (medium).
  - If there is great resistance, it is thoroughly cooked through ("well done").

## Grilling chart

Food	Function	🌡️ [°C]	💧 [%]	🕒 [min]
<b>Fish</b>				
Trout		Level 3	–	25–30
Salmon		180	–	35
Mackerel		Level 3	–	25
<b>Meat / sausages</b>				
Rissoles		Level 3	–	20
Bratwurst fresh / pre- cooked		Level 3	–	15–20
<b>Miscellaneous</b>				
Toast		Level 3	–	5–8
Toast with toppings		Level 3	–	8–15
Corn on the cob		Level 3	30	23

🌡️ Temperature / Grill level / 💧 Moisture / 🕒 Duration

 Full grill /  Fan grill /  Combi mode Full grill

# Settings

---

## Opening the Settings menu

- Select Settings .



A list of settings will appear in the display.

You can check them or change them.







A tick ✓ next to an option shows which setting is active.

Settings cannot be changed while a cooking programme is in progress.

## Changing and saving settings

- Select Settings .
- Scroll through the list until the setting you want appears.
- Touch the sensor next to the setting.  
The setting you want may need to be selected from a sub menu.
- Change the setting.
- Confirm with *OK*.
- Touch  until the main menu appears or select another setting.

## Settings overview

Option	Available settings
Language 	... / deutsch / english / ... Country
Time	Show On / Off * / Night dimming Clock format 24 h * / 12 h Set
Date	
Lighting	On / On for 15 seconds *
Display brightness	
Acoustic information	Melody  Solo tone 
Keypad tone	
Units	Weight g * / lb / lb:oz Temperature °C * / °F
Keeping warm	On / Off *
Automatic rinse	On * / Off
Steam reduction	On * / Off
Recommended temps.	
Safety	System lock  On / Off * Sensor lock On / Off *
Water hardness	Soft Medium Hard *
Showroom programme	Demo mode On / Off *
Factory default	Settings User programmes Recommended temps.

\* Factory default setting



# Settings

---

## Language

You can set the language and the country you want.

After selecting and confirming your choice, the language you have selected will appear in the display.



**Tip:** If you have selected the wrong language by mistake, select the  symbol to get back to the Language  menu.

## Time of day



### Display

Select how you want the time of day to show in the display when the steam oven is switched off:

- On

The time of day always appears in the display. You can switch the lighting  on and off, use the minute minder  or open and close the control panel  by touching the relevant sensor.

- Off

The display is switched off to save energy. The steam oven has to be switched on before you can use it. This also applies to using the oven interior lighting , the minute minder  and opening and closing the control panel .

- Night dimming

To save energy the time is only shown in the display between 05:00 and 23:00. The rest of the time it is not visible.

## Clock format

You can select whether the time shows as a 24 h or 12 h clock.

- 24 h

The time of day is shown in 24 hour clock format.

- 12 h

The time of day is shown in 12 hour clock format.

## Setting the time

Set the hours and the minutes.

If there is an interruption to the power supply, the current time of day will reappear once power has been restored. The time is stored in memory for about 200 hours.

## Date

Set the date.

When the steam oven is switched off the date will only show if the following settings have been set: Time | Show | On or Night dimming (between 05:00 h and 23:00 h).

## Lighting

- On  
The interior lighting is switched on during the entire cooking period.
- On for 15 seconds  
The oven lighting turns off 15 seconds after a programme starts. Touching  switches it on for another 15 seconds.

## Display brightness

The display brightness is represented by a bar with seven segments.



- Select **Darker** or **Brighter** to change the brightness of the display.

## Acoustic information

### Melody

At the end of a process, a melody will sound several times in intervals.

The volume of the melody is represented by a bar with seven segments.



Maximum volume is selected when all segments are filled. If none of the segments are filled the volume is switched off.

- Select **Quieter** or **Louder**, to adjust the volume.
- Select **On** or **Off** to switch the melody on or off.

### Solo tone

At the end of a process, a continuous tone will sound for a period of time.

The pitch of this tone is represented by a segment bar.

- Select **Lower** or **Higher**, to change the pitch.

# Settings

---

## Keypad tone

An audible tone is heard each time a sensor is touched.

The volume of the keypad tone is represented by a bar with seven segments.



Maximum volume is selected when all segments are filled. If none of the segments are filled the volume is switched off.

- Select **Quieter** or **Louder**, to adjust the volume.
- Select **On** or **Off** to switch the keypad tone on or off.

## Units

### Weight

– g

Weight in Automatic programmes is set using grammes.

– lb

Weight in Automatic programmes is set using pounds.

– lb:oz

Weight in Automatic programmes is set using pounds and ounces.

### Temperature

– °C

The temperature is displayed in degrees Celsius.

– °F

The temperature is displayed in degrees Fahrenheit.

## Keeping warm

Please note that delicate food, especially fish, can continue cooking whilst being kept warm.

### – On

The warming function is activated as standard with the Steam cooking function if a temperature above approx. 80 °C is selected. If food is not removed from the oven at the end of a programme, the warming function will automatically start after approx. 5 minutes. Keeping warm will appear in the display and the food will be kept warm for approx. 15 minutes at a temperature of 70 °C. The warming function is cancelled when a sensor is touched or the door is opened.

### – Off

The keeping warm function has been deactivated.

## Automatic rinsing

Following a cooking programme with steam Appliance rinsing will appear in the display after the steam oven has been switched off.

Any remaining food deposits are flushed out of the system.

You can activate or deactivate the automatic rinsing process.

## Steam reduction

### – On

The steam reduction function will switch on automatically at the end of a cooking programme which uses a temperature of over approx. 80 °C (steam cooking) or 80-100 °C and 100% moisture (Combi mode). This reduces the amount of steam which escapes when the door is opened. Steam reduction will appear in addition to Process finished in the display.

### – Off

If steam reduction is switched off the Keeping warm function is also automatically switched off. If steam reduction is switched off a large amount of steam will escape when the door is opened.

# Settings

---

## Recommended temperatures

If you cook with different temperatures often it makes sense to change the recommended temperatures.

Once the option has been selected the list of functions and special applications with the relevant recommended temperatures will appear in the display.

- Select the function / special application you want.

The recommended temperature will appear together with the range within which it can be changed.

- Change the recommended temperature.
- Confirm with OK.

## Safety

### System lock

The system lock prevents the appliance being switched on by mistake.

The minute minder can still be used when the system lock is active.

The system lock will remain activated even after a power failure.

- On

The system lock is active. If you want to use the steam oven touch the sensor next to OK for at least 6 seconds.

- Off

The system lock is not active. You can use the steam oven as normal.

## Sensor lock

The sensor lock prevents the oven being switched off by accident or settings being altered whilst food is cooking. Once activated, the sensor lock prevents the sensors working a few seconds after a programme has been started.

### – On

The sensor lock is activated. Touch the sensor next to *OK* for at least 6 seconds to use the functions again. The sensor lock is then deactivated for a short period.

### – Off

The sensor lock is not active. All sensors react to touch as normal.

## Water hardness

The steam oven is set ex-works for Hard water. It must be adjusted to local water hardness to ensure trouble-free operation and to ensure that descaling is carried out at the correct interval. The harder the water, the more often it will need to be descaled.

### – Soft

< 8.4 °dH, < 1.5 mmol/l

### – Medium

8.4 - 14 °dH, 1.5 - 2.5 mmol/l

### – Hard

> 14 °dH, > 2.5 mmol/l

# Settings

---

## Showroom programme

This function enables the steam oven to be demonstrated in showrooms without heating up. It should not be set for domestic use.

## Demo mode

If demo mode is activated Demo mode active. The appliance will not heat up **will** appear when the steam oven is switched on.

### – On

Touch the sensor next to OK for at least 4 seconds to activate demo mode.

### – Off

Touching the sensor next to OK for at least 4 seconds will deactivate Demo mode. You can then use the steam oven as normal.

## Factory default

### – Settings

Any settings that you have altered will be reset to their factory default settings.

### – User programmes







All user programmes will be deleted.





### – Recommended temps.

Recommended temperatures which have been changed will be reset to their factory default settings.

## Note for test institutes

### Test food in accordance with EN 60350-1 (Steam cooking function)

Test food	Cooking containers	Quantity [g]			 * [°C]	 [min]
Steam replenishment						
Broccoli (8.1)	1x DGGL 12	max.	2		100	3
Steam distribution						
Broccoli (8.2)	1x DGGL 20	300	2		100	3
Performance at maximum capacity						
Peas (8.3)	2x DGGL 12	1500 g in each	1, 3		100	**















 Shelf level(s) /  Temperature /  Function /  Steam cooking /  Duration

\* Place the test food in a cold oven (before the heating-up phase begins).





\*\* The test is finished when the temperature measures 85 °C in the coolest place.

## Note for test institutes

### Test food according to EN 50304 / EN 60350 (oven functions)

Test food	Bakeware	Function		 [°C]	 ** [min]	Pre-heating	
Drop cookies	1 baking tray		3	140	36–42 (36)	No	Yes
	2 baking trays		1, 3 *	140	40–46 (41)	No	Yes
	1 baking tray		3	140	26–30 (28)	Yes	Yes
Small cakes	1 baking tray		2	150	30–34 (30)	No	Yes
Whisked sponge cake	1 springform cake tin 26 cm (on rack)		2	180	31–34 (31)	No	Yes
			2	180	22–26 (24)	Yes	Yes
Apple pie	1 springform cake tin 20 cm (on rack)		2	160	100–110 (105)	No	Yes
			2	160	88–92 (90)	Yes	Yes
Toast	Rack		4	Level 3	3	6 min	No
Beef burgers	Rack on top of universal tray		4	Level 3	1st side 14 2nd side 10	5 min	No

 Shelf level /  Temperature/grill level /  Duration /  Select Rapid heat-up

 Fan plus /  Conventional heat /  Cake plus /  Full grill

\* Take the baking trays out of the oven early if the food is sufficiently browned before the specified duration has elapsed.

\*\* The value in brackets states the optimum cooking duration.

### Energy efficiency class

This appliance is rated energy efficiency class A in accordance with EN 50304. Tests were carried out using Gentle bake.

## Important information on cleaning and care



**Danger of injury.**

The steam from a steam cleaning appliance could reach electrical components and cause a short circuit.

Do not use a steam cleaner to clean the steam oven.

All surfaces can become discoloured or damaged if unsuitable cleaning agents are used. The front of the steam oven, in particular, will be damaged by oven cleaners.

All surfaces are susceptible to scratching. Scratches on glass surfaces could cause a breakage in certain circumstances.

Remove any residual cleaning agent immediately.

Stubborn soiling could damage the steam oven in certain circumstances. Clean the oven interior, inside of the door and door seal as soon as the oven has cooled down. Waiting too long can make cleaning unnecessarily difficult and in some cases impossible.

Do not use commercial cleaning agents. Only use cleaning agents designed for domestic use.

Do not use cleaning agents or washing-up liquids containing aliphatic hydrocarbons as these could cause the seals to swell.

Allow the appliance to cool down to a safe temperature before cleaning.

- The appliance and accessories should be cleaned and dried thoroughly after each use.
- Leave the appliance door open until the oven interior is completely dry.

If the appliance is not going to be used for a longer period of time, e.g. whilst on holiday, it should be thoroughly cleaned and dried beforehand to prevent the build-up of odours etc. Leave the door open afterwards.

# Cleaning and care

---

## Unsuitable cleaning agents

To avoid damaging the surfaces, do not use:

- cleaning agents containing soda, ammonia, acids or chlorides
- cleaning agents containing descaling agents
- abrasive cleaning agents, e.g. powder cleaners and cream cleaners
- solvent-based cleaning agents
- stainless steel cleaning agents
- dishwasher cleaner
- glass cleaning agents
- cleaning agents for ceramic hobs
- hard, abrasive brushes or sponges, e.g. pot scourers, brushes or sponges which have been previously used with abrasive cleaning agents
- melamine eraser blocks
- sharp metal scrapers or tools
- wire wool
- stainless steel spiral pads
- spot cleaning
- oven sprays.

## Appliance front

Soiling that is left too long might become impossible to remove and could cause external surfaces to alter or discolour.

Remove any soiling immediately.

- Clean the front with a solution of warm water and a little washing-up liquid applied with a clean sponge or cloth. A clean, damp microfibre cloth without cleaning agent can also be used.
- After cleaning dry the front of the appliance with a soft cloth.

### PerfectClean

The oven interior and side runners are made from stainless steel which has been treated with a special

**PerfectClean** finish which gives the surface an iridescent appearance.

PerfectClean surfaces have very good non-stick properties and are easy to clean.

However, it is very important to clean the surfaces each time the oven is used.

The surface will become harder to clean and the non-stick properties will deteriorate if soiling is not removed after each use and allowed to build up.

Soiling such as spilt juices and cake mixtures are best removed whilst the oven or tray is still warm. Exercise caution, make sure the oven is not hot.

Spilt fruit juices may cause discolouration of the surfaces. This discolouration is permanent but will not affect the efficiency of the surface.

Remove residual cleaning agent after cleaning. If left it will reduce the non-stick properties of the PerfectClean surfaces.

### To protect the non-stick effect of PerfectClean surfaces please avoid:

- abrasive cleaning agents, e.g. powder cleaners and cream cleaners
- cleaning agents for ceramic hobs
- ceramic and stainless steel hob cleaner
- wire wool
- abrasive sponges, e.g. pot scourers or sponges which have been previously used with abrasive cleaning agents
- oven sprays
- cleaning in the dishwasher
- spot cleaning

## Cleaning and care

---

Do not use oven spray as you will not be able to remove all residual chemicals.

### Oven interior

The surface of the oven compartment has been treated with PerfectClean.

Please refer to the section on "PerfectClean" for information on cleaning and care.

The oven door (see "Door") and the side runners (see "Side runners") can be removed to make it easier to clean the oven interior.

#### After a programme using steam

- Remove:
  - condensate using a sponge or absorbent cloth,
  - light, greasy soiling with a sponge and a solution of washing-up liquid and hot water.
- After cleaning, wipe the surface with a damp cloth to remove any cleaning agent residues.
- Then dry the oven interior and the inside of the door with a cloth.

**Tip:** You can then leave the oven to dry automatically (see "Maintenance / Drying").

#### After a roasting, grilling or baking programme

Clean the oven thoroughly after roasting, grilling and baking as otherwise soiling can burn on and become impossible to remove.

- Remove light soiling from the oven compartment and the inside of the door with a clean non-scouring washing-up sponge and a solution of washing-up liquid and hot water. If necessary, the pad on the reverse of the sponge can be used to clean the oven compartment.
- After cleaning, wipe the surface with a damp cloth to remove any cleaning agent residues.
- Then dry the oven interior and the inside of the door with a cloth.

**Tip:** Soaking the soiling for a few minutes with a solution of washing-up liquid and hot water can make cleaning easier. Alternatively run the Maintenance | Soak programme (see "Maintenance - Soak").

## Floor filter

- The filter in the floor of the oven should be cleaned and dried after every use.
- Vinegar can be used to remove discolouration and limescale deposits from the filter in the floor of the oven. Rinse thoroughly with clean water afterwards.

## Door seal

Grease deposits on the seal between the inside of the oven door and the oven interior can cause it to become brittle and cracked.

- Clean the door seal after every baking or roasting programme using a clean, damp microfibre cloth or a clean sponge and a solution of washing-up liquid and hot water.
- After cleaning dry the seal with a soft cloth.
- Replace the seal with a new one if it becomes porous or brittle.

Door seals can be ordered from the Miele Spare Parts Department (see the end of this booklet for contact details).

## Grease filter

Clean the grease filter after every roasting programme.

The grease filter can be cleaned in a dishwasher.

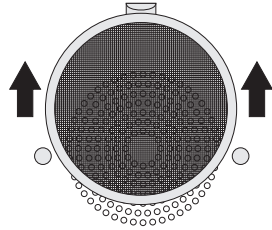

- Pull the grease filter upwards to remove it.
- The grease filter can be cleaned in the dishwasher or by hand with a solution of warm water and a little washing-up liquid applied with a clean sponge.

If the grease filter is cleaned in the dishwasher, results are better if the filter is placed horizontally in the basket. Some dishwasher detergents may cause the surface of the filter to discolour. This discolouration will not affect the functioning of the filter in any way.

# Cleaning and care

---

## Water container and condensate container

The water container and condensate container are suitable for cleaning in a dishwasher.

- Remove and empty the water container and condensate container after every use. Push upwards slightly as you take them out of the appliance.

Water can drip into the water container and condensate container compartment when removing the containers.

- Dry the compartment with a soft cloth.
- Rinse the water container / condensate container by hand or in the dishwasher.
- Then dry the water container and condensate container with a soft cloth to prevent limescale.

## Accessories

### Cooking containers

The cooking containers are suitable for cleaning in the dishwasher.

- Wash and dry the cooking containers after each use.
- Any bluish discolouration on cooking containers can be removed with vinegar. Rinse with clean water.

## Universal tray and Combi rack

The surface of the universal tray and the combi rack have been treated with a PerfectClean finish.

Do not clean the universal tray and combi rack in the dishwasher.

Please refer to the section on "PerfectClean" for information on cleaning and care.

- Remove:
  - light soiling with a sponge and a solution of washing-up liquid and hot water.
  - heavier soiling with a clean non-scouring washing-up sponge and a solution of washing-up liquid and hot water. If necessary, the pad on the reverse of the sponge can be used.
- After cleaning, wipe the surface with a damp cloth to remove any cleaning agent residues.
- Dry the surface of the universal tray and the combi rack with a soft cloth.

## Food probe

Do not immerse the food probe in water or clean it in the dishwasher as this will damage it.

- Clean the food probe with a damp cloth after every use.

## Side runners

The surface of the side runners has been treated with PerfectClean. Do not clean the side runners in the dishwasher.

Please refer to the section on "PerfectClean" for information on cleaning and care.

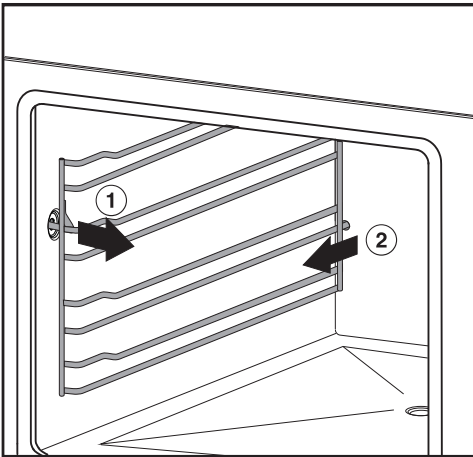

- Pull the side runners out first from the side ①, then from the back ② of the steam oven.

### ■ Remove:

- light soiling with a clean sponge and a solution of washing-up liquid and hot water.

- heavier soiling with a clean non-scouring washing-up sponge and a solution of washing-up liquid and hot water. If necessary, the pad on the reverse of the sponge can be used.

- After cleaning wipe with clean water to remove any detergent residues.
- Dry the side runners with a soft cloth.
- Push the side runners firmly back in after cleaning. When putting them back in, make sure they are correctly inserted (see illustration).

If the side runners are not correctly inserted there is no anti-tip protection. The temperature sensor could also be damaged when cooking containers are placed in the steam oven.

# Cleaning and care

---

## Maintenance

The Ready at and Start at functions are not available in the Maintenance programme.

### Soak

Stubborn soiling from roasting can be soaked using this programme.

- Allow the oven interior to cool down.
- Remove all accessories from the oven.
- Fill the water container.
- Select Maintenance | Soak.

The soaking process takes approx. 10 minutes.

### Drying

Use this programme to dry the oven interior, including inaccessible areas thoroughly.

- Dry the oven interior with a soft cloth.
- Select Maintenance | Drying.

The drying process takes approx. 20 minutes.

### Rinsing

This programme is used for flushing out components in the appliance that carry water and ensures any food deposits are also removed.

- Select Maintenance | Rinses.
- Follow the instructions in the display.

Rinsing takes approx. 10 minutes.

## Descaling

We recommend using Miele descaling tablets for descaling the appliance (see "Optional accessories"). These have been specially developed for Miele appliances to optimise the descaling process. Other descaling agents, which contain other acids besides citric acid and/or other undesirable substances, such as chlorides, for example, could damage the steam oven. Moreover, the descaling effect required could not be guaranteed if the descaling solution was not of the appropriate concentration.

Descaling solution is acidic.

Do not spill descaling agent onto metal surfaces. This can cause marks to appear.

However, should any descaling agent get onto these surfaces, wipe it away immediately.

The steam oven needs to be descaled after a certain number of operating hours. When the steam oven needs to be descaled, a number will appear in the display indicating the number of cooking processes remaining before the appliance locks out. Only cooking processes using steam are counted. After the last remaining cooking process, the appliance will lock out.

We recommend that you descale the appliance before it locks out.

During the descaling process the water container must be rinsed out and refilled with fresh water and the condensate container must be emptied.

- Switch the steam oven on and select Maintenance | Descale.

The message *Please wait...* will appear in the display. The descaling process is being primed and may take a few minutes. As soon as the appliance is ready you will be prompted to fill the water container.

- Fill the water container with cold fresh tap water up to the level marker  and drop 2 Miele descaling tablets in it.
- Push the water container into the appliance until it connects.
- Confirm with OK.
- Empty the condensate container.
- Confirm with OK.

The descaling process will now begin and the duration remaining will count down in the display.

It is only possible to cancel the descaling process during the first 6 minutes. Do not switch the appliance off during the descaling process. If it is switched off before the end of the process, the whole process will have to be started from the beginning again.

The water container will need emptying and rinsing twice and refilling with fresh tap water during descaling. The condensate container must be emptied.

- Follow the instructions in the display.
- Confirm each with OK.

Once this has taken place Empty the condensate container will appear in the display.

- Follow the instructions in the display.
- Confirm with OK.

The descaling process is complete.

### After descaling

- Remove, empty and dry the water container and condensate container.
- Switch the steam oven off.
- Allow the oven compartment to cool down.
- Then dry the oven compartment.
- Leave the appliance door open until the oven interior is completely dry.

# Cleaning and care

## Door

### To remove the oven door

- Prepare a suitable underlay for the door, such as a soft cloth.
- Open the door a fraction.

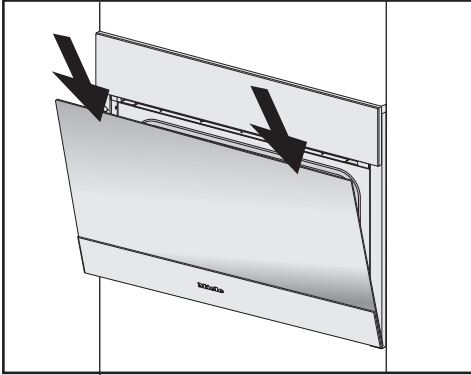

- Using both hands press down on the top edge of the door briefly.

Before removing the door, the locking clamps on both hinges have to be released.

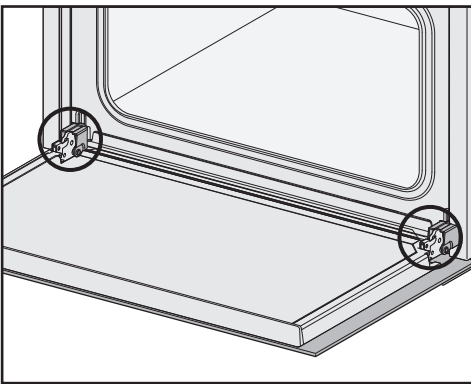

- Open the door fully.

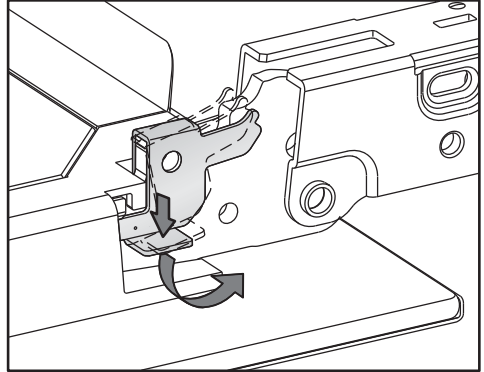

- To release the locking clamps on the hinges turn them upwards as far as they will go until they are at an angle.

**⚠** Danger of injury from the hinge retainers for the door.

The hinge retainers retract to the steam oven.

Do not attempt to take the door off when it is in a horizontal position.

- Raise the door up till it rests open.

Risk of damage to the door.

The door handle may break off and the glass may be damaged.

The door should be gripped firmly at the sides and not by the handle when being removed.

Make sure that the door goes back on straight.

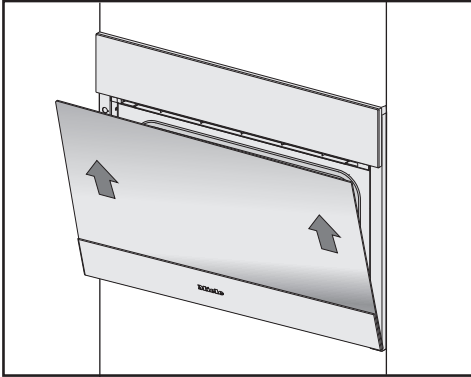

- Hold the door securely at both sides and lift it evenly upwards off the hinge retainers.
- Place the door on the previously prepared surface.

## Refitting the door

Risk of damage to the door.  
Make sure that the door goes back on straight.

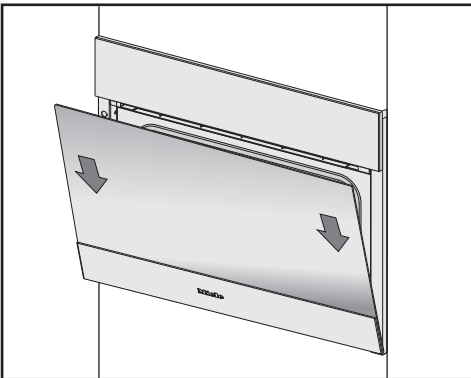

- Hold the door securely at both sides and carefully fit it back onto the hinge retainers.

Risk of damage to the door.  
If the locking clamps are not locked, the door could work loose resulting in damage.

Ensure that the locking clamps are locked after refitting the door.

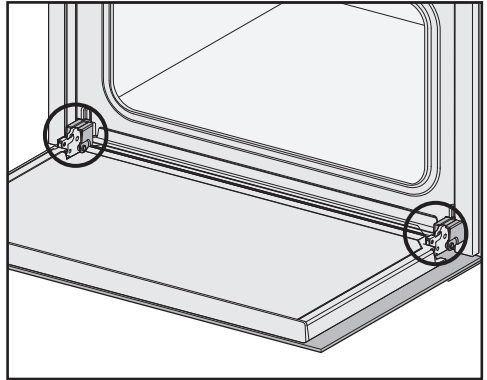

- Open the door fully.

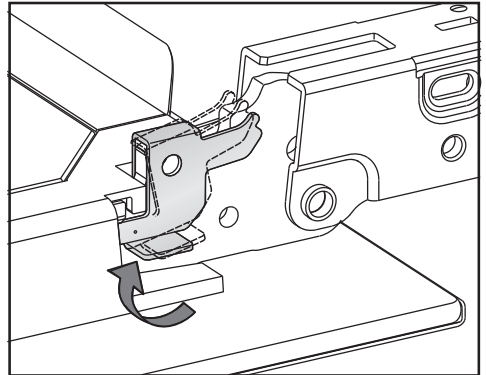

- Turn both locking clamps up as far as they will go into a horizontal position.

## Problem solving guide

With the aid of the following guide, minor problems can be easily corrected without contacting Miele.

If having followed the suggestions below, you still cannot resolve the problem, please contact Miele (see back cover for contact details).

 **Danger of injury.** Installation, maintenance and repairs to electrical appliances must only be carried out by a suitably qualified and competent person in strict accordance with current local and national safety regulations. Do not open the casing of the appliance. Repairs and other work by unqualified persons could be dangerous and Miele cannot be held liable for unauthorised work.

Problem	Cause and remedy
<b>You cannot switch the appliance on.</b>	The fuse is defective or has tripped. ■ Reset the trip switch in the mains fuse box or replace the fuse (minimum fuse rating - see data plate).
	There may be a technical fault. ■ Disconnect the appliance from the mains connection for approx. 1 minute: – switch off at the isolator, or – disconnect the mains fuse. ■ If, after resetting the trip switch in the mains fuse box and switching the appliance back on, the appliance will still not heat up, contact a qualified electrician or Miele.
<b>The oven does not heat up.</b>	Demo mode has been activated. The steam oven can be operated but does not heat up. ■ Deactivate demo mode. See "Settings - Showroom programme".
	The oven cavity has been warmed up by a warming drawer in operation underneath it. ■ Open the door and let the oven cool down.
<b>The fan can still be heard after the appliance has been switched off.</b>	The fan is still running. The appliance is fitted with a fan which removes steam from the oven. The fan will continue to run for a while after the appliance has been switched off. It will switch itself off automatically after a while.

## Problem solving guide

Problem	Cause and remedy
<b>A humming sound can be heard after switching on the appliance, during operation and after switching off the appliance.</b>	It is quite normal and does not indicate any fault with the appliance. It happens when water is being pumped through the system.
<b>After moving house the appliance no longer switches from the heating-up phase to the cooking phase.</b>	<p>The boiling temperature of the water has changed as the altitude of the new location for the appliance differs from the old one by at least 300 m.</p> <ul style="list-style-type: none"> <li>■ To adjust the boiling temperature, you need to descale the appliance (see "Cleaning and care - Descaling").</li> </ul>
<b>During operation an unusually large amount of steam escapes, or steam escapes from parts of the oven where it does not usually.</b>	<p>The door is not properly closed.</p> <ul style="list-style-type: none"> <li>■ Close the door.</li> </ul>
	<p>The door seal is not correctly fitted.</p> <ul style="list-style-type: none"> <li>■ Press it in all the way round the door to make sure it is fitted evenly.</li> </ul>
	<p>The door seal is damaged, e.g. cracks can be seen.</p> <ul style="list-style-type: none"> <li>■ Replace the door seal. This can be ordered from Miele (see the end of this booklet for contact details).</li> </ul>
<b>The oven interior lighting is not working.</b>	<p>The lamp is defective.</p> <ul style="list-style-type: none"> <li>■ Call Miele Service to have the lamp replaced.</li> </ul>
<b>The control panel will not open or close automatically despite touching the  sensor several times.</b>	<p>Something is obstructing the control panel.</p> <ul style="list-style-type: none"> <li>■ Remove the obstruction.</li> </ul>
	<p>The obstruction sensor is very sensitive and can prevent the panel opening or shutting if it picks up a signal.</p> <ul style="list-style-type: none"> <li>■ Open/close the control panel manually (see end of this section)</li> <li>■ If the problem occurs again, contact Miele Service.</li> </ul>
<b>The <small>Start at</small> and <small>Ready at</small> functions have not worked.</b>	<p>The temperature in the oven is too high, e.g. after a programme has finished.</p> <ul style="list-style-type: none"> <li>■ Open the door and let the oven cool down.</li> </ul>
	<p>These functions are not available with <small>Menu cooking</small> and <small>Maintenance</small>.</p>

## Problem solving guide

Problem	Cause and remedy
<b>Cakes and biscuits are not cooked properly after following the durations given in the recipe.</b>	The temperature set is not the same as the one given in the recipe. ■ Change the temperature.
	The grease filter is inserted in the back panel. Baking takes longer with this filter in place. ■ Increase the baking duration.
	The recipe has been altered. For example, adding more liquid or eggs can increase the duration required. ■ Adapt the temperature or baking duration accordingly.
<b>Cakes or biscuits are unevenly browned.</b>	The set temperature is too high.
	The grease filter has not been taken out of the back panel.
	More than two levels were used for baking. ■ Bake on a maximum of two levels.
F10	The suction tube in the water container – is not fitted correctly. – is not positioned vertically. ■ Connect it properly and make sure it is vertical: <div data-bbox="631 914 815 1070" data-label="Image"> <p>The diagram shows a cross-section of a water container with a suction tube. The tube is shown being inserted into a port. A vertical line indicates the correct orientation, ensuring the tube is perfectly vertical. The container has a lid and a base.</p> </div>
F11 F20	The drain hoses are blocked. ■ Proceed as described in "Cleaning and care - Descaling". ■ If the fault message appears again, switch the appliance off and contact Miele.
F44	Communication fault ■ Switch the steam oven off and then back on again after a few minutes. ■ If the same message appears again, call the Service Department.

## Problem solving guide

Problem	Cause and remedy
F55	<p>The maximum operating time for a cooking function has been exceeded. This has triggered the safety switch off device.</p> <ul style="list-style-type: none"><li>■ Switch the steam oven off and then back on again.</li></ul> <p>The steam oven is immediately ready for use again.</p>
F196	<p>There is a fault.</p> <ul style="list-style-type: none"><li>■ Switch the steam oven off and then back on again.</li></ul> <p>The filter in the bottom of the oven is not positioned correctly.</p> <ul style="list-style-type: none"><li>■ Switch the steam oven off.</li><li>■ Insert the filter correctly:</li></ul> <div data-bbox="680 619 770 724" data-label="Image"></div> <ul style="list-style-type: none"><li>■ Switch the steam oven back on again.</li><li>■ If, having corrected the problem, this fault message appears again, contact Miele Service.</li></ul>
<b>F and other fault codes</b>	<p>Technical fault.</p> <ul style="list-style-type: none"><li>■ Switch the appliance off and contact Miele.</li></ul>

## Problem solving guide

---

### To open the panel manually

- Carefully open the appliance door.

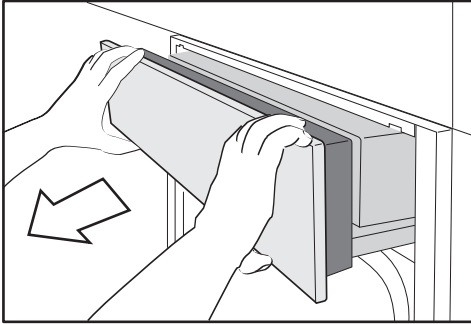

- Take hold of the panel at the top and bottom.
- Pull the panel out forwards to start with.
- Then carefully push the panel upwards.

### To close the panel manually

- Take hold of the panel at the top and bottom.
- Carefully push the panel downwards.

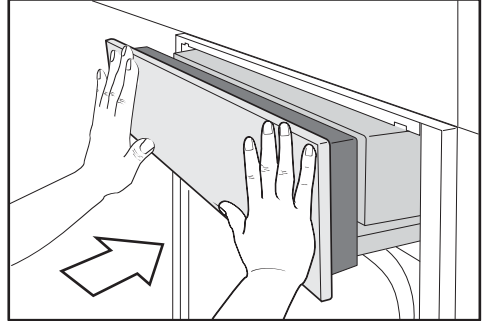

- Then push it in.

Miele offer a comprehensive range of useful accessories as well as cleaning and conditioning products for your Miele appliances.

These products can be ordered through the Miele Webshop.

These can also be ordered from Miele (see end of this booklet for contact details) or from your Miele dealer.

### Cooking containers

There is a wide range of perforated and solid cooking containers available in different sizes:

Cooking containers **325** mm wide are not suitable for sliding into the oven on the runners and must be placed on the container rack.

#### DGGL 1

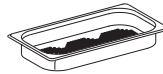

Perforated cooking container  
Gross capacity 1.5 litres / Usable capacity 0.9 litres  
325 x 175 x 40 mm (W x D x H)

#### DGG 2

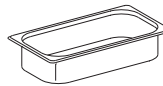

Solid cooking container  
Gross capacity 2.5 litres / Usable capacity 2.0 litres  
325 x 175 x 65 mm (W x D x H)

#### DGG 3

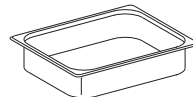

Solid cooking container  
Gross capacity 4.0 litres / Usable capacity 3.1 litres  
325 x 265 x 65 mm (W x D x H)

# Optional accessories

---

## DGGL 4

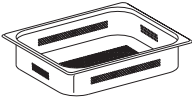

Perforated cooking container  
Gross capacity 4.0 litres / Usable capacity 3.1 litres  
325 x 265 x 65 mm (W x D x H)

## DGGL 5

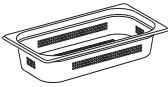

Perforated cooking container  
Gross capacity 2.5 litres / Usable capacity 2.0 litres  
325 x 175 x 65 mm (W x D x H)

## DGGL 6

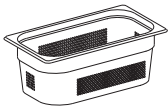

Perforated cooking container  
Gross capacity 4.0 litres / Usable capacity 2.8 litres  
325 x 175 x 100 mm (W x D x H)

## DGG 7



Solid cooking container  
Gross capacity 4.0 litres / Usable capacity 2.8 litres  
325 x 175 x 100 mm (W x D x H)

## DGGL 8

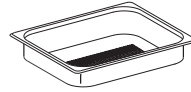

Perforated cooking container  
Gross capacity 2.0 litres / Usable capacity 1.7 litres  
325 x 265 x 40 mm (W x D x H)

## DGGL 12



Perforated cooking container  
Gross capacity 5.4 litres / Usable capacity 3.3 litres  
450 x 390 x 40 mm (W x D x H)

## DGG 20

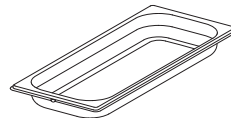

Solid cooking container  
Gross capacity 2.4 litres / Usable capacity 1.8 litres  
450 x 190 x 40 mm (W x D x H)

## DGGL 20

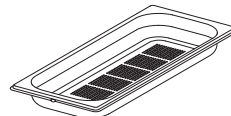

Perforated cooking container  
Gross capacity 2.4 litres / Usable capacity 1.8 litres  
450 x 190 x 40 mm (W x D x H)

## Optional accessories

---

### Lid for cooking containers

**DGD 1/3**



Lid for 325 x 175 mm cooking containers

**DGD 1/2**

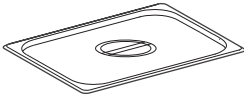

Lid for 325 x 265 mm cooking containers

### Cleaning and care products

**DGCLean (250 ml)**



Special cleaning agent for removing stubborn soiling from the oven interior, particularly after roasting.

**Descaling tablets (Qty 6)**



For descaling the appliance

**Microfibre cloth**

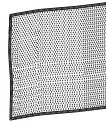

Removes finger marks and light soiling

# Optional accessories

---

## Miscellaneous

### Universal tray

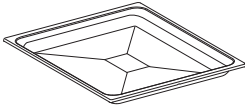

Universal tray for baking, roasting and grilling

### Combi rack



Combi rack for baking, roasting and grilling

### Food probe

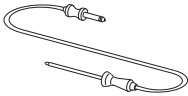

For precise temperature controlled cooking. The food probe monitors the inner temperature of the meat (core temperature).

### FlexiClip telescopic runners

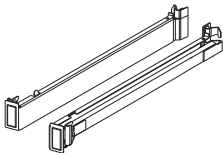

The FlexiClip telescopic runners can be clipped into any of the existing shelf runners and pulled out of the oven to their fullest extent.

## Container rack

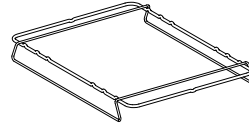

For holding 325 mm wide containers. Slides into the side runners in the appliance.

## Round baking tray

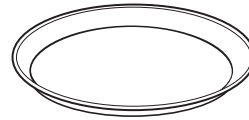

Suitable for cooking pizzas, flat cakes made with yeast or whisked mixtures, sweet and savoury tarts, baked desserts, and can also be used for deep frozen cakes and pizzas.

Not suitable for use with programmes using steam.

### Gourmet oven dishes

Die-cast aluminium oven dish with non-stick surface. Slides into the side runners in the oven. Also suitable for use on an extended zone of an electric ceramic hob.

Not suitable for use on gas hobs or induction hobs.

#### HUB 5000-M

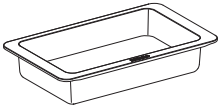

Maximum capacity approx. 5.0 kg  
Depth 22 cm

#### HUB 5000-XL

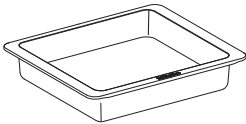

Maximum capacity approx. 8.0 kg  
Depth 35 cm

### Lid for Gourmet oven dish

Stainless steel

#### HBD 60-22

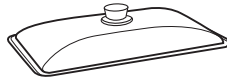

Suitable for HUB 5000-M

#### HBD 60-35

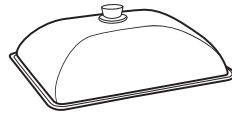

Suitable for HUB 5000-XL

### Miele@home

The Miele@home System can only be fitted by an authorised Miele service technician. Please contact Miele for details of this system. It is not available in all countries.

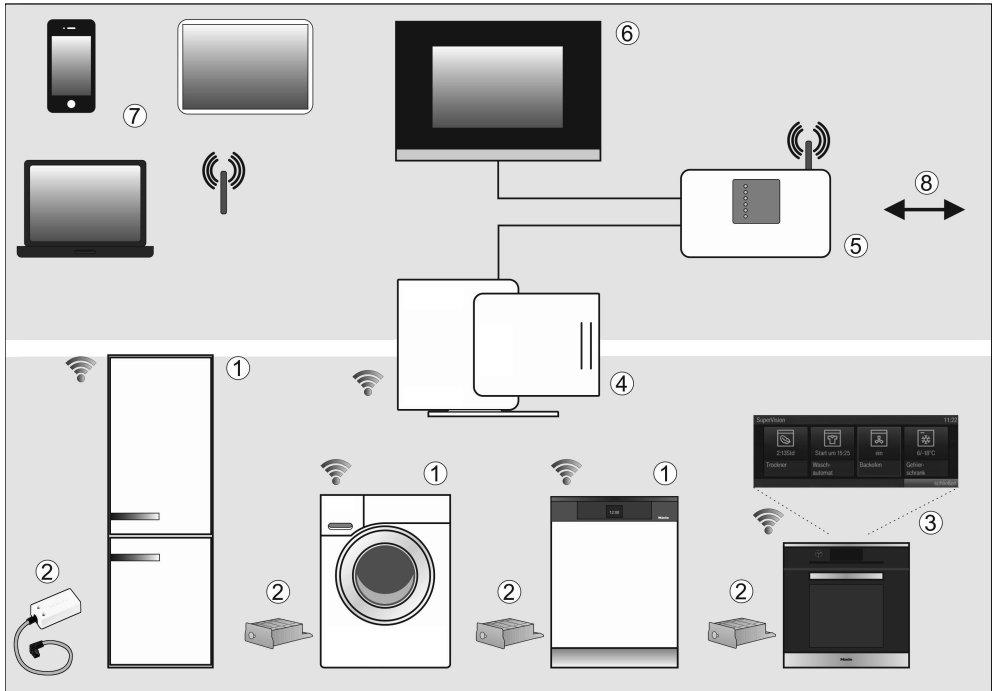

- ① Miele@home communication enabled appliance
- ② Miele@home communication stick XKS3000Z or communication module XKM3000Z
- ③ Miele@home communication enabled Master appliance with SuperVision functionality
- ④ Miele@home Gateway XGW3000
- ⑤ WiFi router
- ⑥ Connection to a Home automation system
- ⑦ Smartphone, Tablet PC, Laptop
- ⑧ Internet connection

## **Please note that the Miele@home and SuperVision system is currently only available in selected countries.**

This appliance ①/③ is network enabled and can be connected to the Miele@home system via a communication module or communication stick ② and a conversion kit where required.

The Miele@home system enables network enabled appliances to send information via the household wiring network to a master appliance ③ such as an oven with SuperVision functionality, about their operational status, as well as information about the progress of the programme.

## **Displaying information and controlling appliances**

- SuperVision master appliance ③  
The status of other signed on appliances can be shown in the display of some network enabled appliances.
- Mobile device ⑦  
A PC, Notebook, Tablet PC or a Smartphone can be used within the reception area of a household WLAN ⑤ to display status information about signed on appliances and carry out certain functions.
- Household network ⑥  
The Miele@home system enables smart living. The Miele@home Gateway ④ allows other network enabled appliances to integrate into the household bus system.

- In Germany, network enabled appliances can be integrated into the QIVICON Smart Home Platform instead of the Miele@home Gateway ([www.qivicon.de](http://www.qivicon.de)).

## **SmartStart (depending on household appliance)**

Smart grid enabled appliances can be started automatically at a time when electricity costs are favourable or when a favourable supply of electricity is available (e.g. from a solar power system).

## **Optional accessories (depending on household appliance)**

- Communication module XKM3000Z or communication stick XKS3000Z
- Conversion kit for communication system XKV
- Miele@home Gateway XGW3000

These accessories are supplied with their own installation and operating instructions.

## **Further information**

Further information regarding Miele@home is available on the internet and in the instruction manuals of the various Miele@home components.

## Safety instructions for installation

---

 Incorrect installation can result in personal injury and damage to property.

- ▶ Before connecting the appliance to the mains supply, ensure that the connection data on the data plate (voltage and frequency) match the mains electricity supply. This data must correspond in order to avoid the risk of damage to the appliance. Consult a qualified electrician if in any doubt.
- ▶ Do not connect the steam oven to the mains electricity supply by a multi-socket adapter or an extension lead. These do not guarantee the required safety of the appliance (fire hazard).
- ▶ The socket and on-off switch should be easily accessible after the appliance has been installed.
- ▶ The appliance must be positioned so that you can see the contents of a cooking container placed on the top runner. Otherwise you may risk scalding or burning yourself with hot water and food when taking containers out of the oven.

All dimensions are given in mm.

# Detailed dimensions of oven front

## PureLine front

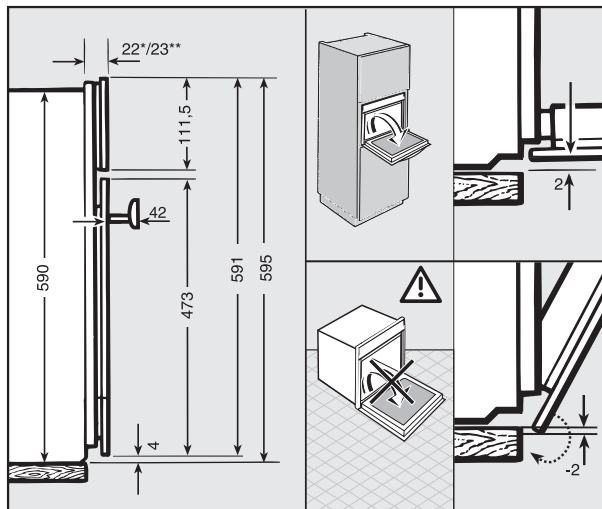

## ContourLine front

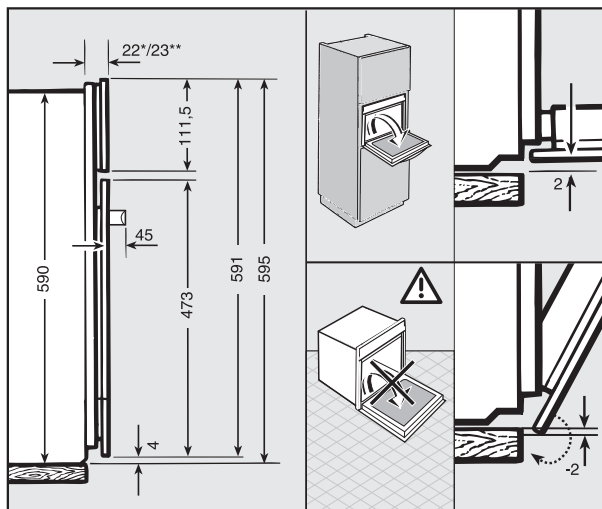

\* Glass front / \*\* metal front

# Detailed dimensions of oven front

## Room for control panel to open and shut

The area in front of the control panel must not be blocked by anything (such as a door handle) that would hinder it from opening and shutting.

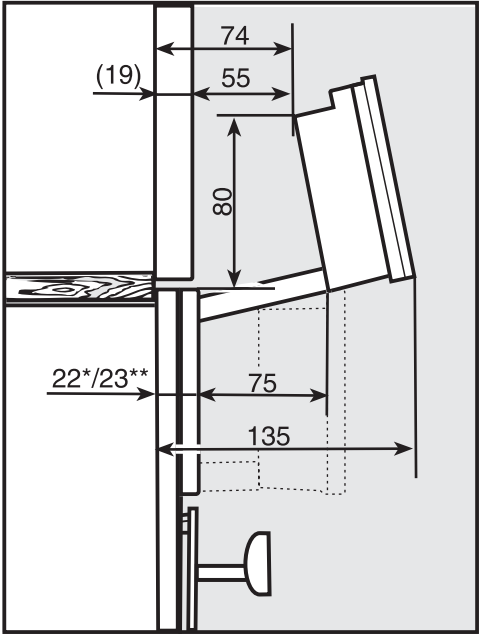

\* Glass front / \*\* metal front



# Building-in dimensions

---

## Ventilation cut-outs for the steam oven

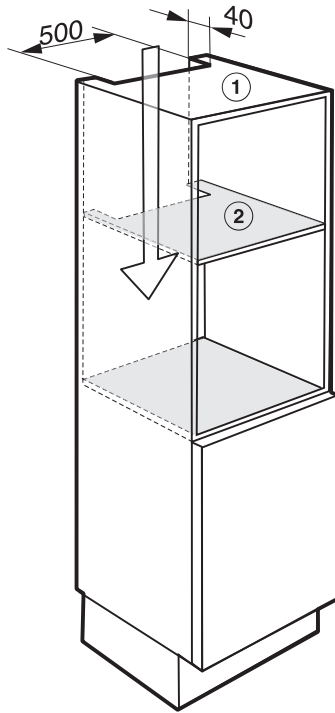

- ① Cut-out in the top of the unit
- ② Cut-out in the interim shelf above the building-in niche

## Installation in a base unit

The furniture housing unit must not have a back panel fitted behind the building-in niche.

When building the appliance into a base unit underneath a hob please also observe the installation instructions for the hob as well as the building-in depth required for the hob (see installation instruction manual for the hob).

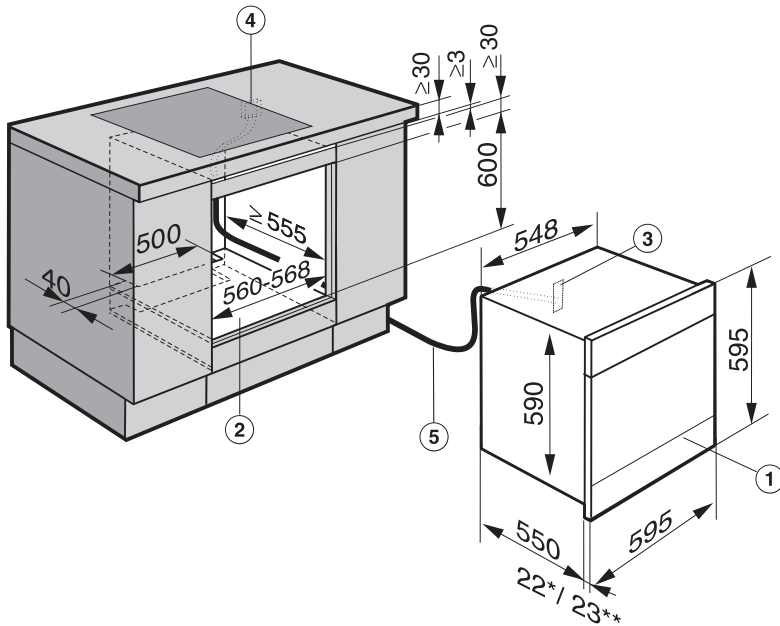

- ① Steam oven
- ② Niche
- ③ Inlet for mains connection cable to the appliance
- ④ Recommended position for electrical socket. Important: Do not position behind the appliance.
- ⑤ Mains connection cable

\* Glass front / \*\* metal front

# Building-in dimensions

---

## Ventilation cut-outs for the steam oven

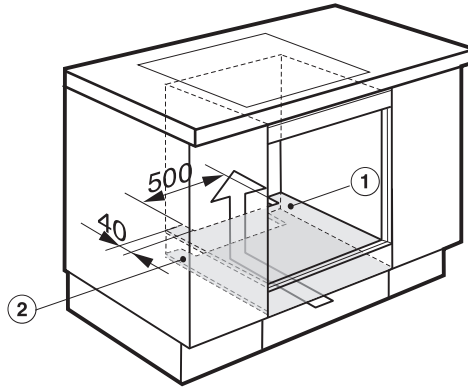

- ① Cut-out in the interim shelf at the bottom of the building-in niche
- ② Cut-out in unit floor

## Installing the steam oven

A malfunction can occur if the steam oven is not correctly aligned.

For correct functioning of the steam generator please make sure that the steam oven is horizontally level. The maximum deviation tolerated is 2°.

- Push the steam oven into position in the niche and align it. Make sure that the mains connection cable does not get trapped or damaged when doing so.

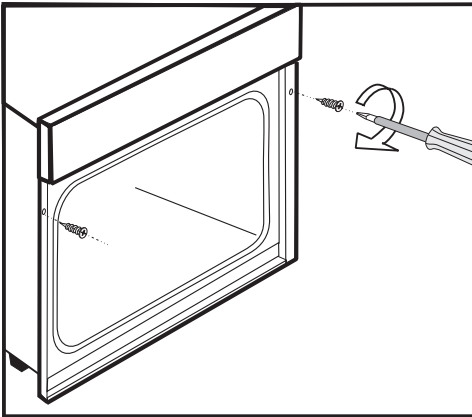

- Secure the steam oven using the wood screws supplied (3.5 mm x 25 mm) to the left and right hand sides of the unit.
- Connect the appliance to the electricity supply.
- Check the appliance for correct function in accordance with the operating instructions.

# Electrical connection

---

All electrical work should be carried out by a suitably qualified and competent person in strict accordance with current local and national safety regulations (e.g. BS 7671 in the UK). Connection should be made via a switched socket. This will make it easier for service technicians should the appliance need to be repaired. The electrical socket must be easily accessible after installation.



**Danger of injury.**

Miele cannot be held liable for unauthorised installation, maintenance and repair work as this can be dangerous to users.

Miele cannot be held liable for damage or injury caused by incorrect installation, maintenance or repair work, or by an inadequate or faulty earthing system (e.g. electric shock).

If the plug is removed from the connection cable or if the cable is supplied without a plug, the appliance must be connected to the electrical supply by a suitably qualified electrician.

If the switched socket is not accessible after installation, or if the appliance is to be hard-wired, an additional means of disconnection must be provided for all poles. When switched off, there must be an all-pole contact gap of at least 3 mm in the switch (including switch, fuses and relays). Connection data is shown on the data plate. It must match the mains electrical supply.

After installation ensure that all electrical components are shielded and cannot be accessed by users.

## Total power rating

See data plate

## Connection

AC 230 V, 50 Hz

The connection data is quoted on the data plate. It must match the household supply.

## Residual current device

For extra safety, it is advisable to protect the appliance with a suitable residual current device (RCD) with a trip range of 30 mA.

## Disconnecting from the mains

 Danger of electrical shock.  
After disconnection, ensure the appliance cannot be switched back on by mistake.

To disconnect the appliance from the mains power supply, do one of the following depending on installation:

### Safety fuses

- Completely remove fuses

### Automatic circuit breakers

- Press the (red) button until the middle (black) button springs out.

### Built-in circuit breakers

Circuit breakers type B or C:

- Switch the on/off switch from 1 (on) to 0 (off).

### Residual current device (RCD)

- Switch the main switch from 1 (on) to 0 (off) or press the test button.

## Connecting the mains cable

 Danger of electric shock.  
The mains connection cable must only be fitted by a suitably qualified and competent person.

If the mains cable needs to be replaced it must be replaced with a special connection cable, type H 05 VV-F (PVC-insulated), available from Miele.

## Wiring diagram

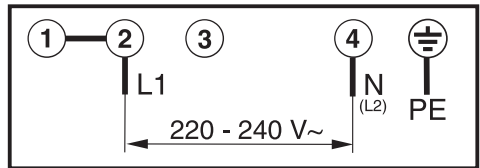

## After sales service, data plate, guarantee

---

### After sales service

In the event of any faults which you cannot easily remedy, please contact

- your Miele Dealer, or
- Miele Service.

See end of this booklet for contact details.

Please note that telephone calls may be monitored and recorded for training purposes.

N.B. A call-out charge will be applied to service visits where the problem could have been resolved as described in these instructions.

When contacting your Dealer or Miele, please quote the model and serial number of your appliance.

### Data plate

Space in which to stick the extra data plate supplied with the appliance. Ensure that the model number is the same as the one on the back page of these instructions.

### Guarantee: UK

The appliance is guaranteed for 2 years from the date of purchase.

In the UK, you must activate your cover by calling 0330 160 6640 or registering online at [www.miele.co.uk](http://www.miele.co.uk).

### Guarantee: Other countries

For information on the appliance guarantee specific to your country please contact Miele. See end of this booklet for contact details.





## United Kingdom

Miele Co. Ltd.  
Fairacres, Marcham Road  
Abingdon, Oxon, OX14 1TW  
Customer Contact Centre Tel: 0330 160 6600  
E-mail: mielecare@miele.co.uk  
Internet: www.miele.co.uk

## Australia

Miele Australia Pty. Ltd.  
ACN 005 635 398  
ABN 96 005 635 398  
1 Gilbert Park Drive, Knoxfield, VIC 3180  
Tel: 1300 464 353  
Internet: www.miele.com.au

## China

Miele (Shanghai) Trading Ltd.  
1-3 Floor, No. 82 Shi Men Yi Road  
Jing' an District  
200040 Shanghai, PRC  
Tel: +86 21 6157 3500, Fax: +86 21 6157 3511  
E-mail: info@miele.cn, Internet: www.miele.cn

## Miele (Hong Kong) Limited

41/F - 4101, Manhattan Place  
23 Wang Tai Road  
Kowloon Bay, Hong Kong  
Tel: (852) 2610 1025, Fax: (852) 3579 1404  
Email: customerservices@miele.com.hk  
Website: www.miele.hk

## India

Miele India Pvt. Ltd.  
Ground Floor, Copia Corporate Suites  
Plot No. 9, Jasola, New Delhi - 110025  
Tel: 011-46 900 000, Fax: 011-46 900 001  
E-mail: customercare@miele.in, Internet: www.miele.in

## Ireland

Miele Ireland Ltd.  
2024 Bianconi Avenue  
Citywest Business Campus, Dublin 24  
Tel: (01) 461 07 10, Fax: (01) 461 07 97  
E-Mail: info@miele.ie, Internet: www.miele.ie

## Manufacturer: Miele & Cie. KG

Carl-Miele-Straße 29, 33332 Gütersloh, Germany

# Miele

## Malaysia

Miele Sdn Bhd  
Suite 12-2, Level 12  
Menara Sapura Kencana Petroleum  
Solaris Dutamas No. 1, Jalan Dutamas 1  
50480 Kuala Lumpur, Malaysia  
Phone: +603-6209-0288  
Fax: +603-6205-3768

## New Zealand

Miele New Zealand Limited  
IRD 98 463 631  
Level 2, 10 College Hill  
Freemans Bay, Auckland 1011, NZ  
Tel: 0800 464 353  
Internet: www.miele.co.nz

## Singapore

Miele Pte. Ltd.  
163 Penang Road  
# 04 - 03 Winsland House II  
Singapore 238463  
Tel: +65 6735 1191, Fax: +65 6735 1161  
E-Mail: info@miele.com.sg  
Internet: www.miele.sg

## South Africa

Miele (Pty) Ltd  
63 Peter Place, Bryanston 2194  
P.O. Box 69434, Bryanston 2021  
Tel: (011) 875 9000, Fax: (011) 875 9035  
E-mail: info@miele.co.za  
Internet: www.miele.co.za

## United Arab Emirates

Miele Appliances Ltd.  
Gold & Diamond Park  
Office No. 217-6, Sheikh Zayed Road  
P.O. Box 11 47 82 - Dubai  
Tel: +971 4 3044 999  
Fax: +971 4 3418 852  
800-MIELE (643353)  
E-Mail: info@miele.ae  
Internet: www.miele.ae

DGC 6660



en-GB

M.-Nr. 09 667 380 / 03